

IG Instrumental Rated Servomotors

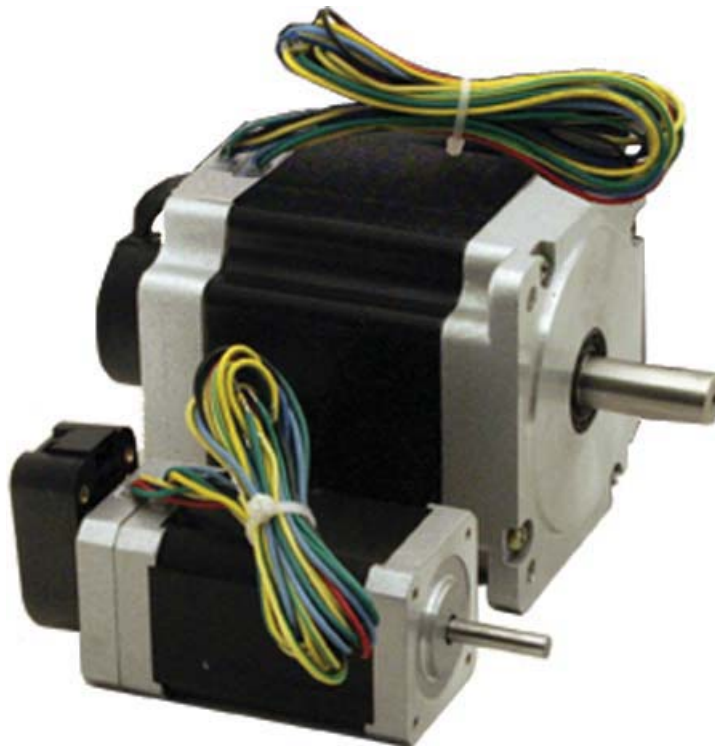

The IG Instrument Rated DC brushless three-phase servomotor delivers high continuous torque in a cost reduced package and with an IP40 environmental rating.

The increased torque is the result of eight magnetic poles on the rotor compared to the traditional four magnetic poles. This design uses neodymium magnets for maximum performance. The IG series has an open-lamination design reducing cost. This series come with NEMA standard flanges size 17, 23, 34, and 42 with continuous torque rating from 25 to 820 oz-in (0.18 to 5.80 Nm). The IG's can come with halls sensors or without and with or without a rear shaft. The IG's can also be supplied with an incremental optical encoder with or without hall simulation tracks. To meet the different global requirements the output shaft comes in Imperial or Metric dimensions. These servomotors are also available with planetary gearheads.

Model Numbering System:

IG 34 A S - 64 - RNC 2000 - F

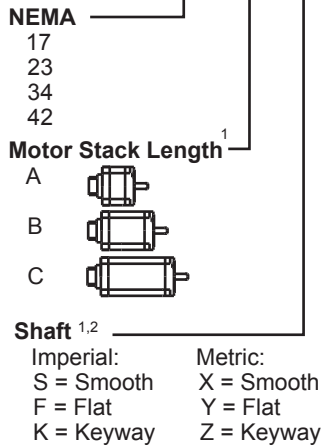

Flying Leads⁴

Feedback Option

- XX = No Halls, No Rear Shaft
- XS = No Halls w/Rear Shaft
- HX = Halls, No Rear Shaft
- HS = Halls w/Rear Shaft
- USX XXXX = US Digital Encoder-pulses per revolution³
- RNC XXXX = Renco Encoder-pulses per revolution w/Commutation Tracks³
- EPC XXXX = Encoder Products-pulses per revolution w/Commutation Tracks³
- QDC XXXX = Quantum Devices-pulses per revolution w/Commutation Tracks³

Voltage Gradient

Refer To Voltage Gradient Availability Table

1. Refer to Dimensions for the exact length and shaft options
2. Keyway shaft is provided only on NEMA 23, 34 and 42 Servomotors
3. Refer to resolution table available for each encoder provided on page 12 and 13 of IG Instrumental Rated Brochure
4. The F housing option comes with 6 inches (15 cm) flying leads

Voltage Gradient Availability Table:

Voltage Constant K_E (V/kRPM)		4	8	11	16	22	32	44	64	88	130	180	260	360
Frame Size	IG 17													
	IG 23													
	IG 34													
	IG 42													

Motor Performance Curves:

There are two cases to select a motor:

Case I: The bus voltage (V_{bus}) and torque (T) are known.

The speed is related to the torque and bus voltage according to the following formula:

$$(1) \quad n = \frac{-b + \sqrt{b^2 - 4ac}}{2a}$$

where

$$a = K_E^2 + \left(\frac{1000\pi PL}{60}\right)^2 \left(\frac{T}{K_T}\right)^2$$

$$b = \frac{2TRK_E}{K_T}$$

$$c = \left(\frac{T}{K_T}\right)^2 R^2 - V_{bus}^2$$

Case II: The bus voltage (V_{bus}) and speed (n) are known.

The torque is related to the speed and bus voltage according to the following formula:

$$(2) \quad T = \frac{-f + \sqrt{f^2 - 4eg}}{2e}$$

where

$$e = \left[R^2 + \left(\frac{1000n\pi PL}{60}\right)^2 \right] \left(\frac{1}{K_T}\right)^2$$

$$f = \frac{2RK_E n}{K_T}$$

$$g = K_E^2 n^2 - V_{bus}^2$$

Definitions of Symbols

- n is the motor speed, krpm.
- V_{bus} is the bus voltage, VDC.
- K_E is the voltage constant, V/krpm.
- K_T is the torque constant, Nm/Amp (peak).
- T is the torque, Nm.
- P is the number of poles. For IG motors, $P=8$.
- R is the motor resistance, Ohm
- L is the motor inductance, Henry.
- p is equal to 3.14

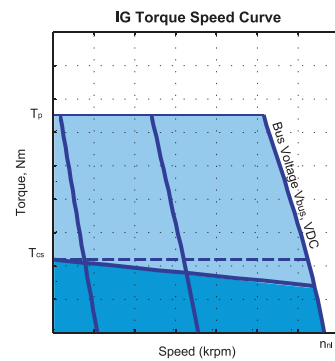

■ Intermittent duty zone
■ Continuous duty zone
 T_p : Peak stall torque
 T_{cs} : Continuous stall torque
 n_0 : No load speed at the bus voltage, V_{bus}

Note: While using Eq. (1) and Eq. (2) you must use values with the above specified units.

Selected Torque-Speed Curves

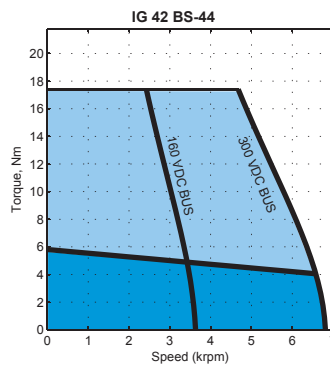
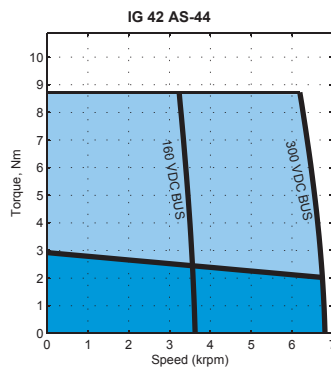
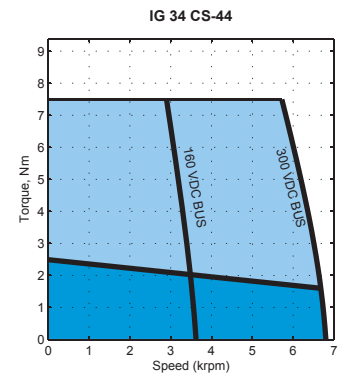
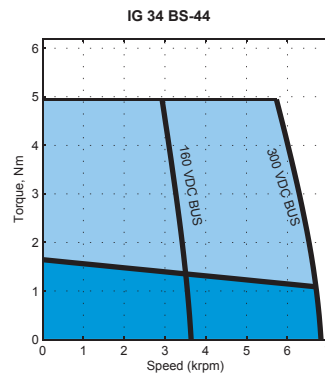
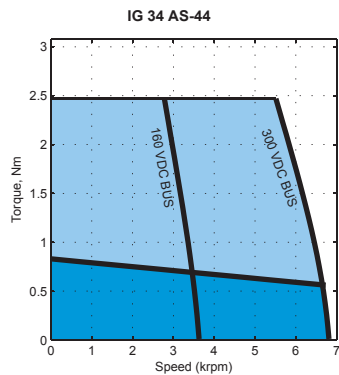
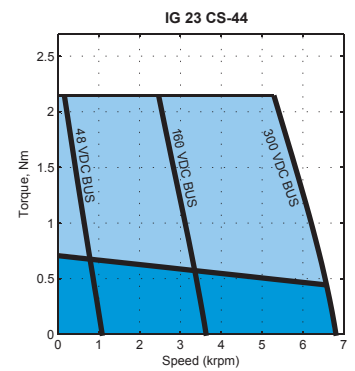
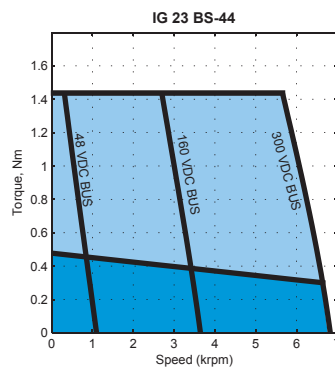
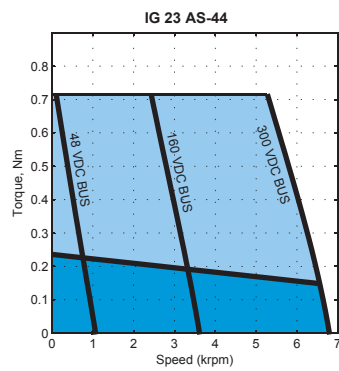
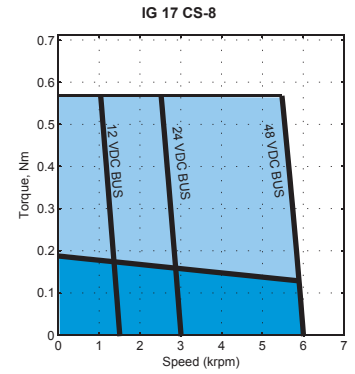
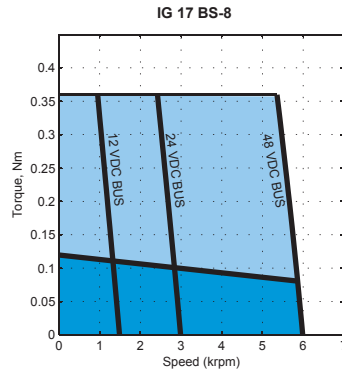
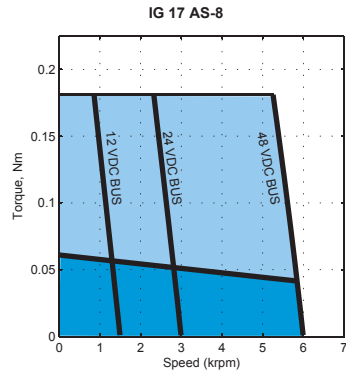

Note:
Contact factory for torque-speed curves of other motors.

NEMA 17																		
Index	Model Number	Weight		Torque Constant (Peak) (L2L)		Voltage Constant	Cont. Stall Torque		Cont. Stall Current	Peak Stall Torque		Peak Stall Current	Max BEMF (Peak) (L2L)	Max Speed	L-to-L Resistance	L-to-L Inductance	Rotor Inertia	
		W		K _T		K _E	T _{cs}		I _{cs}	T _p		I _p	U _{max}	n _{max}	R	L	J	
		kg	lb	Nm/A	lb-in/A	V/krpm	Nm	lb-in	A	Nm	lb-in	A	V	rpm	Ohms	mH	kg-cm ²	lb-in-sec ²
1	IG 17 AS - 4	0.32	0.71	0.04	0.39	4.00	0.06	0.53	1.36	0.18	1.59	4.08	32.00	8000	0.62	0.53	0.13	0.00012
2	IG 17 BS - 4	0.48	1.06	0.04	0.39	4.00	0.12	1.06	2.72	0.36	3.19	8.16	32.00	8000	0.27	0.28	0.26	0.00023
3	IG 17 CS - 4	0.63	1.39	0.04	0.39	4.00	0.19	1.71	4.38	0.57	5.04	12.92	32.00	8000	0.14	0.13	0.39	0.00035
4	IG 17 AS - 8	0.32	0.71	0.09	0.78	8.00	0.06	0.53	0.68	0.18	1.59	2.04	64.00	8000	2.50	2.10	0.13	0.00012
5	IG 17 BS - 8	0.48	1.06	0.09	0.78	8.00	0.12	1.06	1.36	0.36	3.19	4.08	64.00	8000	1.05	1.00	0.26	0.00023
6	IG 17 CS - 8	0.63	1.39	0.09	0.78	8.00	0.19	1.71	2.19	0.57	5.04	6.46	64.00	8000	0.58	0.50	0.39	0.00035
7	IG 17 AS - 11	0.32	0.71	0.12	1.07	11.00	0.06	0.53	0.49	0.18	1.59	1.48	88.00	8000	5.90	4.70	0.13	0.00012
8	IG 17 BS - 11	0.48	1.06	0.12	1.07	11.00	0.12	1.06	0.99	0.36	3.19	2.97	88.00	8000	2.30	2.15	0.26	0.00023
9	IG 17 CS - 11	0.63	1.39	0.12	1.07	11.00	0.19	1.71	1.59	0.57	5.04	4.70	88.00	8000	0.70	1.25	0.39	0.00035
10	IG 17 AS - 16	0.32	0.71	0.18	1.56	16.00	0.06	0.53	0.34	0.18	1.59	1.02	128.00	8000	10.50	8.40	0.13	0.00012
11	IG 17 BS - 16	0.48	1.06	0.18	1.56	16.00	0.12	1.06	0.68	0.36	3.19	2.04	128.00	8000	4.10	4.00	0.26	0.00023
12	IG 17 CS - 16	0.63	1.39	0.18	1.56	16.00	0.19	1.71	1.09	0.57	5.04	3.23	128.00	8000	1.20	2.34	0.39	0.00035

NEMA 23																		
Index	Model Number	Weight		Torque Constant (Peak) (L2L)		Voltage Constant	Cont. Stall Torque		Cont. stall current	Peak Stall Torque		Peak Stall Current	Max BEMF (Peak) (L2L)	Max Speed	L-to-L Resistance	L-to-L Inductance	Rotor Inertia	
		W		K _T		K _E	T _{cs}		I _{cs}	T _p		I _p	U _{max}	n _{max}	R	L	J	
		kg	lb	Nm/A	lb-in/A	V/krpm	Nm	lb-in	A	Nm	lb-in	A	V	rpm	Ohms	mH	kg-cm ²	lb-in-sec ²
13	IG 23 AS - 8	0.62	1.37	0.09	0.78	8.00	0.24	2.12	2.72	0.72	6.37	8.16	64.00	8000	0.60	0.72	0.30	0.00027
14	IG 23 BS - 8	0.96	2.12	0.09	0.78	8.00	0.48	4.25	5.44	1.44	12.75	16.32	64.00	8000	0.28	0.35	0.60	0.00053
15	IG 23 CS - 8	1.20	2.65	0.09	0.78	8.00	0.72	6.37	8.16	2.16	19.12	24.48	64.00	8000	0.21	0.24	0.90	0.00080
16	IG 23 AS - 11	0.62	1.37	0.12	1.07	11.00	0.24	2.12	1.98	0.72	6.37	5.94	88.00	8000	1.40	1.90	0.30	0.00027
17	IG 23 BS - 11	0.96	2.12	0.12	1.07	11.00	0.48	4.25	3.96	1.44	12.75	11.87	88.00	8000	0.55	0.75	0.60	0.00053
18	IG 23 CS - 11	1.20	2.65	0.12	1.07	11.00	0.72	6.37	5.94	2.16	19.12	17.81	88.00	8000	0.45	0.60	0.90	0.00080
19	IG 23 AS - 16	0.62	1.37	0.18	1.56	16.00	0.24	2.12	1.36	0.72	6.37	4.08	128.00	8000	2.65	3.20	0.30	0.00027
20	IG 23 BS - 16	0.96	2.12	0.18	1.56	16.00	0.48	4.25	2.72	1.44	12.75	8.16	128.00	8000	1.00	1.35	0.60	0.00053
21	IG 23 CS - 16	1.20	2.65	0.18	1.56	16.00	0.72	6.37	4.08	2.16	19.12	12.24	128.00	8000	0.78	1.10	0.90	0.00080
22	IG 23 AS - 22	0.62	1.37	0.24	2.15	22.00	0.24	2.12	0.99	0.72	6.37	2.97	176.00	8000	5.90	9.30	0.30	0.00027
23	IG 23 BS - 22	0.96	2.12	0.24	2.15	22.00	0.48	4.25	1.98	1.44	12.75	5.94	176.00	8000	2.20	2.90	0.60	0.00053
24	IG 23 CS - 22	1.20	2.65	0.24	2.15	22.00	0.72	6.37	2.97	2.16	19.12	8.90	176.00	8000	1.80	2.40	0.90	0.00080
25	IG 23 AS - 32	0.62	1.37	0.35	3.12	32.00	0.24	2.12	0.68	0.72	6.37	2.04	256.00	8000	15.20	18.20	0.30	0.00027
26	IG 23 BS - 32	0.96	2.12	0.35	3.12	32.00	0.48	4.25	1.36	1.44	12.75	4.08	256.00	8000	6.20	7.10	0.60	0.00053
27	IG 23 CS - 32	1.20	2.65	0.35	3.12	32.00	0.72	6.37	2.04	2.16	19.12	6.12	256.00	8000	4.60	5.70	0.90	0.00080
28	IG 23 AS - 44	0.62	1.37	0.49	4.29	44.00	0.24	2.12	0.49	0.72	6.37	1.48	352.00	8000	28.50	35.60	0.30	0.00027
29	IG 23 BS - 44	0.96	2.12	0.49	4.29	44.00	0.48	4.25	0.99	1.44	12.75	2.97	352.00	8000	11.50	14.10	0.60	0.00053
30	IG 23 CS - 44	1.20	2.65	0.49	4.29	44.00	0.72	6.37	1.48	2.16	19.12	4.45	352.00	8000	9.10	12.30	0.90	0.00080
31	IG 23 AS - 64	0.62	1.37	0.71	6.25	64.00	0.24	2.12	0.34	0.72	6.37	1.02	512.00	8000	67.20	80.90	0.30	0.00027
32	IG 23 BS - 64	0.96	2.12	0.71	6.25	64.00	0.48	4.25	0.68	1.44	12.75	2.04	512.00	8000	26.90	33.10	0.60	0.00053
33	IG 23 CS - 64	1.20	2.65	0.71	6.25	64.00	0.72	6.37	1.02	2.16	19.12	3.06	512.00	8000	21.30	27.60	0.90	0.00080
34	IG 23 AS - 88	0.62	1.37	0.97	8.59	88.00	0.24	2.12	0.25	0.72	6.37	0.74	704.00	8000	107.00	134.50	0.30	0.00027
35	IG 23 BS - 88	0.96	2.12	0.97	8.59	88.00	0.48	4.25	0.49	1.44	12.75	1.48	704.00	8000	43.30	54.50	0.60	0.00053
36	IG 23 CS - 88	1.20	2.65	0.97	8.59	88.00	0.72	6.37	0.74	2.16	19.12	2.23	704.00	8000	35.80	45.20	0.90	0.00080
37	IG 23 AS - 130	0.62	1.37	1.43	12.69	130.00	0.24	2.12	0.17	0.72	6.37	0.50	1,040.00	8000	170.20	212.50	0.30	0.00027
38	IG 23 BS - 130	0.96	2.12	1.43	12.69	130.00	0.48	4.25	0.33	1.44	12.75	1.00	1,040.00	8000	68.50	86.84	0.60	0.00053
39	IG 23 CS - 130	1.20	2.65	1.43	12.69	130.00	0.72	6.37	0.50	2.16	19.12	1.51	1,040.00	8000	56.70	71.80	0.90	0.00080
40	IG 23 AS - 180	0.62	1.37	1.98	17.57	180.00	0.24	2.12	0.12	0.72	6.37	0.36	1,440.00	8000	307.40	406.50	0.30	0.00027
41	IG 23 BS - 180	0.96	2.12	1.98	17.57	180.00	0.48	4.25	0.24	1.44	12.75	0.73	1,440.00	8000	131.00	166.10	0.60	0.00053
42	IG 23 CS - 180	1.20	2.65	1.98	17.57	180.00	0.72	6.37	0.36	2.16	19.12	1.09	1,440.00	8000	101.00	136.70	0.90	0.00080

L2L: Line-to-Line

IG Motor Specifications

(Version 3.05)



NEMA 34																		
Index	Model Number	Weight		Torque Constant (Peak) (L2L)		Voltage Constant	Cont. Stall Torque		Cont. Stall Current	Peak Stall Torque		Peak Stall Current	Max BEMF (Peak) (L2L)	Max Speed	L-to-L Resistance	L-to-L Inductance	Rotor Inertia	
		W		K _T		K _E	T _{cs}		I _{cs}	T _p		I _p	U _{max}	n _{max}	R	L	J	
		kg	lb	Nm/A	lb-in/A	V/krpm	Nm	lb-in	A	Nm	lb-in	A	V	rpm	Ohms	mH	kg-cm ²	lb-in-sec ²
43	IG 34 AS - 16	1.90	4.19	0.18	1.56	16.00	0.82	7.26	4.65	2.46	21.77	13.94	128.00	8000	0.34	1.10	0.80	0.00071
44	IG 34 BS - 16	2.90	6.39	0.18	1.56	16.00	1.65	14.60	9.35	4.95	43.81	28.06	128.00	8000	0.14	0.45	1.60	0.00142
45	IG 34 CS - 16	3.90	8.60	0.18	1.56	16.00	2.50	22.13	14.17	7.50	66.38	42.51	128.00	8000	0.10	0.39	2.40	0.00212
46	IG 34 AS - 22	1.90	4.19	0.24	2.15	22.00	0.82	7.26	3.38	2.46	21.77	10.14	176.00	8000	0.81	2.50	0.80	0.00071
47	IG 34 BS - 22	2.90	6.39	0.24	2.15	22.00	1.65	14.60	6.80	4.95	43.81	20.40	176.00	8000	0.56	0.95	1.60	0.00142
48	IG 34 CS - 22	3.90	8.60	0.24	2.15	22.00	2.50	22.13	10.30	7.50	66.38	30.91	176.00	8000	0.20	0.70	2.40	0.00212
49	IG 34 AS - 32	1.90	4.19	0.35	3.12	32.00	0.82	7.26	2.32	2.46	21.77	6.97	256.00	8000	2.10	6.30	0.80	0.00071
50	IG 34 BS - 32	2.90	6.39	0.35	3.12	32.00	1.65	14.60	4.68	4.95	43.81	14.03	256.00	8000	0.74	2.70	1.60	0.00142
51	IG 34 CS - 32	3.90	8.60	0.35	3.12	32.00	2.50	22.13	7.08	7.50	66.38	21.25	256.00	8000	0.40	1.47	2.40	0.00212
52	IG 34 AS - 44	1.90	4.19	0.49	4.29	44.00	0.82	7.26	1.69	2.46	21.77	5.07	352.00	8000	3.80	12.30	0.80	0.00071
53	IG 34 BS - 44	2.90	6.39	0.49	4.29	44.00	1.65	14.60	3.40	4.95	43.81	10.20	352.00	8000	1.50	5.50	1.60	0.00142
54	IG 34 CS - 44	3.90	8.60	0.49	4.29	44.00	2.50	22.13	5.15	7.50	66.38	15.46	352.00	8000	1.10	3.50	2.40	0.00212
55	IG 34 AS - 64	1.90	4.19	0.71	6.25	64.00	0.82	7.26	1.16	2.46	21.77	3.49	512.00	8000	8.60	27.70	0.80	0.00071
56	IG 34 BS - 64	2.90	6.39	0.71	6.25	64.00	1.65	14.60	2.34	4.95	43.81	7.01	512.00	8000	3.45	12.30	1.60	0.00142
57	IG 34 CS - 64	3.90	8.60	0.71	6.25	64.00	2.50	22.13	3.54	7.50	66.38	10.63	512.00	8000	2.10	7.80	2.40	0.00212
58	IG 34 AS - 88	1.90	4.19	0.97	8.59	88.00	0.82	7.26	0.85	2.46	21.77	2.54	704.00	8000	13.50	45.20	0.80	0.00071
59	IG 34 BS - 88	2.90	6.39	0.97	8.59	88.00	1.65	14.60	1.70	4.95	43.81	5.10	704.00	8000	5.50	19.00	1.60	0.00142
60	IG 34 CS - 88	3.90	8.60	0.97	8.59	88.00	2.50	22.13	2.58	7.50	66.38	7.73	704.00	8000	3.50	12.50	2.40	0.00212
61	IG 34 AS - 130	1.90	4.19	1.43	12.69	130.00	0.82	7.26	0.57	2.46	21.77	1.72	1,040.00	8000	22.50	72.80	0.80	0.00071
62	IG 34 BS - 130	2.90	6.39	1.43	12.69	130.00	1.65	14.60	1.15	4.95	43.81	3.45	1,040.00	8000	8.30	30.00	1.60	0.00142
63	IG 34 CS - 130	3.90	8.60	1.43	12.69	130.00	2.50	22.13	1.74	7.50	66.38	5.23	1,040.00	8000	5.10	20.00	2.40	0.00212
64	IG 34 AS - 180	1.90	4.19	1.98	17.57	180.00	0.82	7.26	0.41	2.46	21.77	1.24	1,440.00	8000	46.00	141.30	0.80	0.00071
65	IG 34 BS - 180	2.90	6.39	1.98	17.57	180.00	1.65	14.60	0.83	4.95	43.81	2.49	1,440.00	8000	17.60	56.70	1.60	0.00142
66	IG 34 CS - 180	3.90	8.60	1.98	17.57	180.00	2.50	22.13	1.26	7.50	66.38	3.78	1,440.00	8000	10.20	38.00	2.40	0.00212
67	IG 34 AS - 260	1.90	4.19	2.87	25.38	260.00	0.82	7.26	0.29	2.46	21.77	0.86	2,080.00	8000	97.20	295.30	0.80	0.00071
68	IG 34 BS - 260	2.90	6.39	2.87	25.38	260.00	1.65	14.60	0.58	4.95	43.81	1.73	2,080.00	8000	33.50	118.50	1.60	0.00142
69	IG 34 CS - 260	3.90	8.60	2.87	25.38	260.00	2.50	22.13	0.87	7.50	66.38	2.62	2,080.00	8000	20.50	79.00	2.40	0.00212
70	IG 34 AS - 360	1.90	4.19	3.97	35.14	360.00	0.82	7.26	0.21	2.46	21.77	0.62	2,880.00	8000	173.00	568.00	0.80	0.00071
71	IG 34 BS - 360	2.90	6.39	3.97	35.14	360.00	1.65	14.60	0.42	4.95	43.81	1.25	2,880.00	8000	67.30	227.00	1.60	0.00142
72	IG 34 CS - 360	3.90	8.60	3.97	35.14	360.00	2.50	22.13	0.63	7.50	66.38	1.89	2,880.00	8000	18.70	153.00	2.40	0.00212

NEMA 42																		
Index	Model Number	Weight		Torque Constant (Peak) (L2L)		Voltage Constant	Cont. Stall Torque		Cont. Stall Current	Peak Stall Torque		Peak Stall Current	Max BEMF (Peak) (L2L)	Max Speed	L-to-L Resistance	L-to-L Inductance	Rotor Inertia	
		W		K _T		K _E	T _{cs}		I _{cs}	T _p		I _p	U _{max}	n _{max}	R	L	J	
		kg	lb	Nm/A	lb-in/amp	V/krpm	Nm	lb-in	A	Nm	lb-in	A	V	rpm	Ohms	mH	kg-cm ²	lb-in-sec ²
73	IG 42 AS - 32	5.50	12.13	0.35	3.12	32.00	2.90	25.67	8.22	8.70	77.00	24.65	192.00	6000	0.20	1.10	3.00	0.00266
74	IG 42 BS - 32	9.20	20.28	0.35	3.12	32.00	5.80	51.33	16.44	17.40	154.00	49.31	192.00	6000	0.16	1.40	6.00	0.00531
75	IG 42 AS - 44	5.50	12.13	0.49	4.29	44.00	2.90	25.67	5.98	8.70	77.00	17.93	264.00	6000	0.38	2.30	3.00	0.00266
76	IG 42 BS - 44	9.20	20.28	0.49	4.29	44.00	5.80	51.33	11.95	17.40	154.00	35.86	264.00	6000	0.33	2.90	6.00	0.00531
77	IG 42 AS - 64	5.50	12.13	0.71	6.25	64.00	2.90	25.67	4.11	8.70	77.00	12.33	384.00	6000	1.10	5.00	3.00	0.00266
78	IG 42 BS - 64	9.20	20.28	0.71	6.25	64.00	5.80	51.33	8.22	17.40	154.00	24.65	384.00	6000	0.69	6.40	6.00	0.00531
79	IG 42 AS - 88	5.50	12.13	0.97	8.59	88.00	2.90	25.67	2.99	8.70	77.00	8.97	528.00	6000	1.70	8.00	3.00	0.00266
80	IG 42 BS - 88	9.20	20.28	0.97	8.59	88.00	5.80	51.33	5.98	17.40	154.00	17.93	528.00	6000	1.15	10.50	6.00	0.00531
81	IG 42 AS - 130	5.50	12.13	1.43	12.69	130.00	2.90	25.67	2.02	8.70	77.00	6.07	780.00	6000	2.35	12.70	3.00	0.00266
82	IG 42 BS - 130	9.20	20.28	1.43	12.69	130.00	5.80	51.33	4.05	17.40	154.00	12.14	780.00	6000	1.80	16.70	6.00	0.00531
83	IG 42 AS - 180	5.50	12.13	1.98	17.57	180.00	2.90	25.67	1.46	7.50	66.38	3.78	1,080.00	6000	5.80	25.00	3.00	0.00266
84	IG 42 BS - 180	9.20	20.28	1.98	17.57	180.00	5.80	51.33	2.92	15.00	132.76	7.56	1,080.00	6000	3.50	32.00	6.00	0.00531
85	IG 42 AS - 260	5.50	12.13	2.87	25.38	260.00	2.90	25.67	1.01	7.50	66.38	2.62	1,560.00	6000	11.80	50.70	3.00	0.00266
86	IG 42 BS - 260	9.20	20.28	2.87	25.38	260.00	5.80	51.33	2.02	15.00	132.76	5.23	1,560.00	6000	7.50	67.00	6.00	0.00531
87	IG 42 AS - 360	5.50	12.13	3.97	35.14	360.00	2.90	25.67	0.73	7.50	66.38	1.89	2,160.00	6000	20.30	97.80	3.00	0.00266
88	IG 42 BS - 360	9.20	20.28	3.97	35.14	360.00	5.80	51.33	1.46	15.00	132.76	3.78	2,160.00	6000	14.20	128.00	6.00	0.00531

L2L: Line-to-Line

XX Feedback

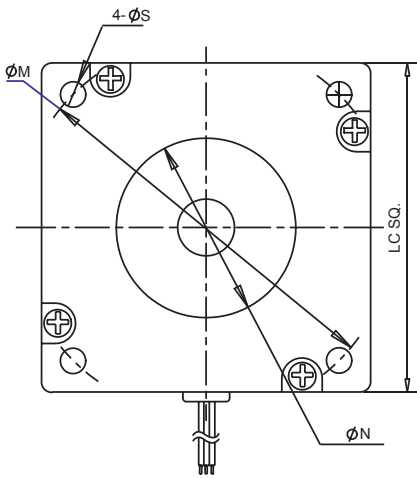

- FRONT SHAFT OPTIONS**
- (1) SMOOTH SHAFT: AS SHOWN IN THE VIEWS.
 - (2) KEYWAY SHAFT
 - (3) FLAT SHAFT

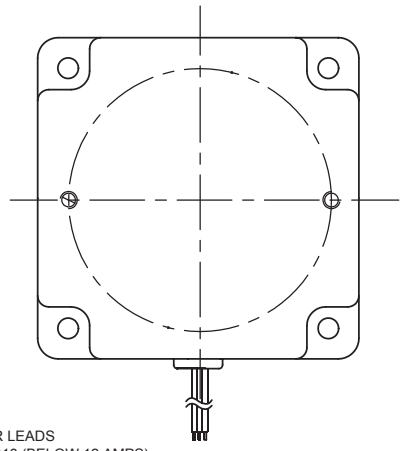
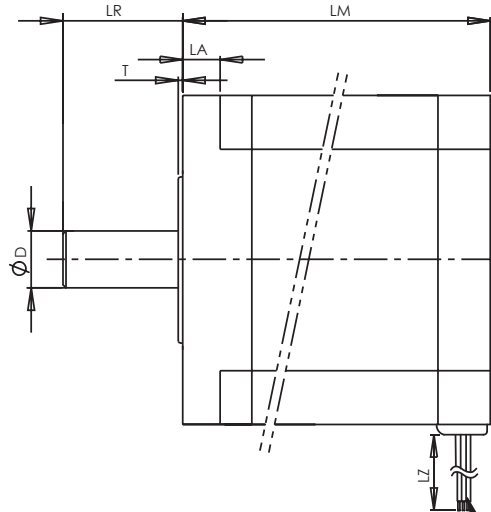

MOTOR LEADS
4XAWG18 (BELOW 12 AMPS)
OR 4XAWG16 (ABOVE 12 AMPS)

NOTE:
THE MOTOR HAS IP40 ENCLOSURE
AND SHAFT PROTECTION.

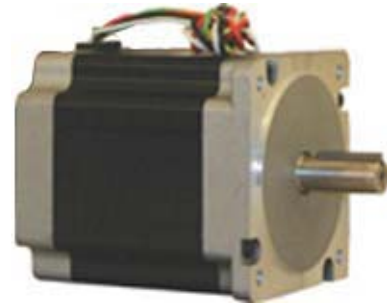
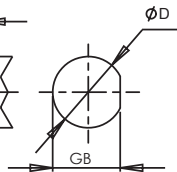
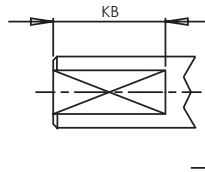
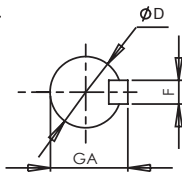
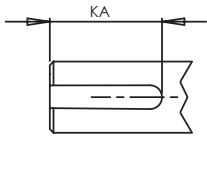

Units: inches (mm)

IG	LM	LA	T	LR	LC	LZ	N	S	M
17	A	1.496 (38)	-	0.079 (2.0)	0.945 (24)	1.665 (42.3)	0.866 ⁰ _{-0.002} (22.00 ⁰ _{-0.05})	0.118 (3.0) ¹	1.725 (43.82)
	B	2.126 (54)							
	C	2.756 (70)							
23	A	1.890 (48)	0.20 (5.1)	0.060 (1.5)	0.825 (21)	2.220 (56.4)	1.500 ⁰ _{-0.002} (38.10 ⁰ _{-0.05})	0.200 (5.1)	2.625 (66.68)
	B	2.717 (69)							
	C	3.543 (90)							
34	A	2.795 (71)	0.33 (8.4)	0.059 (1.5)	1.260 (32)	3.386 (86.0)	2.875 ⁰ _{-0.0012} (73.03 ⁰ _{-0.031})	0.216 (5.5)	3.875 (98.43)
	B	3.858 (98)							
	C	4.921 (125)							
42	A	4.449 (113)	0.49 (12.5)	0.059 (1.5)	2.126 (54)	4.332 (110.0)	2.186 ⁰ _{-0.0018} (55.52 ⁰ _{-0.046})	0.335 (8.5)	4.950 (125.73)
	B	6.811 (173)							
	C	-							

¹ For IG17, dimension S is M3*0.5 min depth 0.2 (5.1) threaded hole

IG	Imperial Shaft Option (S/F/K), Units: inches						Metric Shaft Option (X/Y/Z), Units: mm					
	D	F	GA	KA	GB	KB	D	F	GA	KA	GB	KB
17	0.1969 ⁰ _{-0.0005}	-	-	-	0.177 ⁰ _{-0.004}	0.50	5 ⁰ _{-0.013}	-	-	-	4.5 ⁰ _{-0.1}	12.7
23	0.3750 ⁰ _{-0.0005}	0.0938 ⁰ _{-0.001}	0.416 ⁰ _{-0.002}	0.5	0.340 ⁰ _{-0.004}	0.50	10 ⁰ _{-0.013}	3 ⁰ _{-0.025}	11.2 ⁰ _{-0.051}	15	9.0 ⁰ _{-0.1}	15.0
34	0.5000 ⁰ _{-0.0005}	0.1250 ⁰ _{-0.001}	0.555 ⁰ _{-0.004}	1.0	0.473 ⁰ _{-0.004}	1.00	14 ⁰ _{-0.013}	5 ⁰ _{-0.03}	16.0 ⁰ _{-0.1}	45	13.0 ⁰ _{-0.1}	45.0
42	0.7500 ⁰ _{-0.0005}	0.1875 ⁰ _{-0.0012}	0.830 ⁰ _{-0.004}	1.5	0.709 ⁰ _{-0.004}	1.50	19 ⁰ _{-0.013}	6 ⁰ _{-0.030}	21.5 ⁰ _{-0.1}	45	18.0 ⁰ _{-0.10}	45.0

XS Feedback

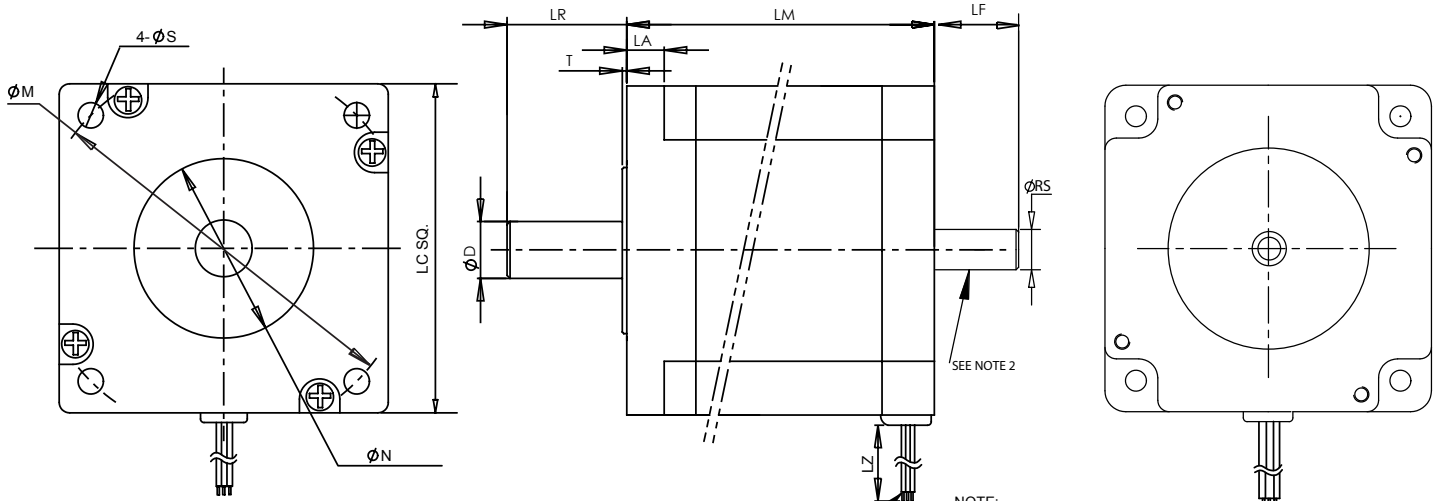

FRONT SHAFT OPTIONS
 (1) SMOOTH SHAFT: AS SHOWN IN THE VIEWS.
 (2) KEYWAY SHAFT
 (3) FLAT SHAFT

4XAWG18 (BELOW 12 AMPS)
 OR 4XAWG16(ABOVE 12 AMPS)
 MOTOR LEADS

NOTE:
 1: THE MOTOR HAS IP40 ENCLOSURE AND SHAFT PROTECTION.
 2: THE AXIAL SHAFT MOVEMENT IS LESS THAN

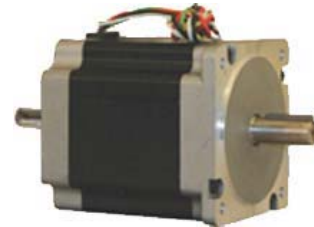
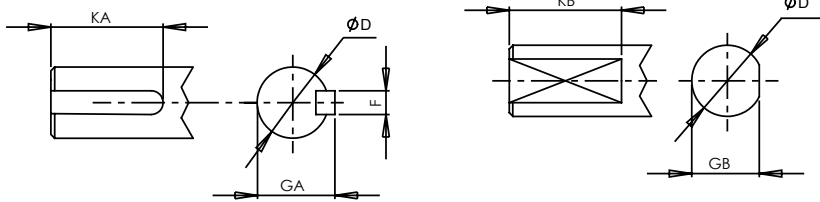

Units: Inches (mm)

IG	LM	LF	LA	T	LR	LC	LZ	ØRS	N	S	M			
17	A	1.496 (38)	-	0.079 (2.0)	0.945 (24)	1.665 (42.3)	12 (304.8)	0.1969 ⁰ _{-0.0005} (5 ⁰ _{-0.013})	0.866 ⁰ _{-0.002} (22.00 ⁰ _{-0.05})	0.118 ¹ (3.0)	1.725 (43.815)			
	B	2.126 (54)							0.866 ⁰ _{-0.002} (22.00 ⁰ _{-0.05})	0.118 ¹ (3.0)	1.725 (43.815)			
	C	2.756 (70)							0.866 ⁰ _{-0.002} (22.00 ⁰ _{-0.05})	0.118 ¹ (3.0)	1.725 (43.815)			
23	A	1.890 (48)	0.20 (5.1)	0.060 (1.5)	0.825 (21)	2.220 (56.4)		0.3150 ⁰ _{-0.0005} (8 ⁰ _{-0.013})	1.500 ⁰ _{-0.002} (38.10 ⁰ _{-0.05})	0.200 (5.1)	2.625 (66.675)			
	B	2.717 (69)	0.20 (5.1)	0.060 (1.5)	0.825 (21)	2.220 (56.4)			1.500 ⁰ _{-0.002} (38.10 ⁰ _{-0.05})	0.200 (5.1)	2.625 (66.675)			
	C	3.543 (90)	0.20 (5.1)	0.060 (1.5)	0.825 (21)	2.220 (56.4)			1.500 ⁰ _{-0.002} (38.10 ⁰ _{-0.05})	0.200 (5.1)	2.625 (66.675)			
34	A	2.795 (71)	0.650 (16.5)	0.33 (8.4)	0.059 (1.5)	1.260 (32)		0.3150 ⁰ _{-0.0005} (8 ⁰ _{-0.013})	2.875 ⁰ _{-0.0012} (73.03 ⁰ _{-0.031})	0.217 (5.5)	3.875 (98.425)			
	B	3.858 (98)										2.875 ⁰ _{-0.0012} (73.03 ⁰ _{-0.031})	0.217 (5.5)	3.875 (98.425)
	C	4.921 (125)										2.875 ⁰ _{-0.0012} (73.03 ⁰ _{-0.031})	0.217 (5.5)	3.875 (98.425)
42	A	4.449 (113)	0.650 (16.5)	0.49 (12.5)	0.059 (1.5)	2.126 (54)		0.3150 ⁰ _{-0.0005} (8 ⁰ _{-0.013})	2.186 ⁰ _{-0.0018} (55.52 ⁰ _{-0.046})	0.335 (8.5)	4.950 (125.730)			
	B	6.811 (173)										2.186 ⁰ _{-0.0018} (55.52 ⁰ _{-0.046})	0.335 (8.5)	4.950 (125.730)
	C	-										2.186 ⁰ _{-0.0018} (55.52 ⁰ _{-0.046})	0.335 (8.5)	4.950 (125.730)

¹ For IG17, dimension S is M3*0.5 min depth 0.2 (5.1) threaded hole

IG	Imperial Shaft Option (S/F/K), Units: Inches						Metric Shaft Option (X/Y/Z), Units: mm					
	D	F	GA	KA	GB	KB	D	F	GA	KA	GB	KB
17	0.1969 ⁰ _{-0.0005}	-	-	-	0.177 ⁰ _{-0.004}	0.50	5 ⁰ _{-0.013}	-	-	-	4.5 ⁰ _{-0.1}	12.7
23	0.3750 ⁰ _{-0.0005}	0.0938 ⁰ _{-0.001}	0.416 ⁰ _{-0.002}	0.50	0.340 ⁰ _{-0.004}	0.50	10 ⁰ _{-0.013}	3 ⁰ _{-0.025}	11.2 ⁰ _{-0.051}	15	9.0 ⁰ _{-0.1}	15.0
34	0.5000 ⁰ _{-0.0005}	0.1250 ⁰ _{-0.001}	0.555 ⁰ _{-0.004}	1.00	0.473 ⁰ _{-0.004}	1.00	14 ⁰ _{-0.013}	5 ⁰ _{-0.03}	16.0 ⁰ _{-0.1}	45	13.0 ⁰ _{-0.1}	45.0
42	0.7500 ⁰ _{-0.0005}	0.1875 ⁰ _{-0.0012}	0.830 ⁰ _{-0.004}	1.50	0.709 ⁰ _{-0.004}	1.50	19 ⁰ _{-0.013}	6 ⁰ _{-0.030}	21.5 ⁰ _{-0.1}	45	18.0 ⁰ _{-0.10}	45.0

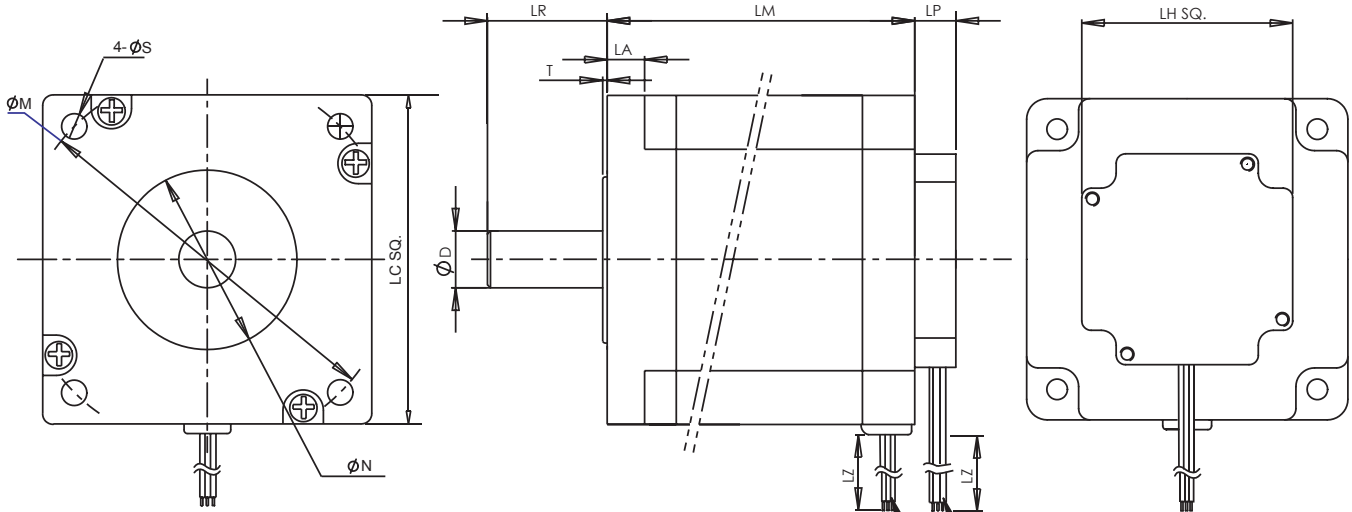

FRONT SHAFT OPTIONS
 (1) SMOOTH SHAFT: AS SHOWN IN THE VIEWS.
 (2) KEYWAY SHAFT
 (3) FLAT SHAFT

NOTE:
 THE MOTOR HAS IP40 ENCLOSURE
 AND SHAFT PROTECTION.

5XAWG24 HALL
 SENSORS LEADS
 4XAWG18 (BELOW 12 AMPS)
 OR 4XAWG16 (ABOVE 12 AMPS)
 MOTOR LEADS

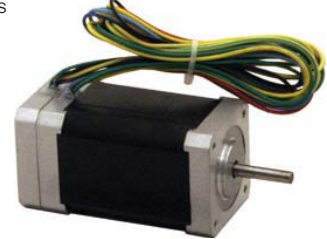
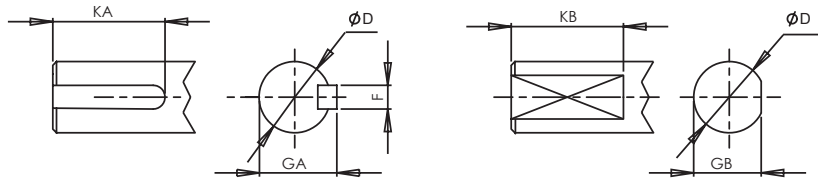

Units: inches (mm)

IG		LM	LA	T	LR	LC	LP	LH	LZ	N	S	M
17	A	1.496 (38)	-	0.079 (2.0)	0.945 (24)	1.665 (42.3)	0.354 (9)	1.665 (42.3)	12 (304.8)	0.866 ⁰ _{-0.002}	0.118 (3.0) ¹	1.725 (43.82)
	B	2.126 (54)								(22.00 ⁰ _{-0.05})	(3.0) ¹	(43.82)
	C	2.756 (70)										
23	A	1.890 (48)	0.20 (5.1)	0.060 (1.5)	0.825 (21)	2.220 (56.4)	0.433 (11)	2.220 (56.4)		1.500 ⁰ _{-0.002}	0.200 (5.1)	2.625 (66.68)
	B	2.717 (69)								(38.10 ⁰ _{-0.05})	(5.1)	(66.68)
	C	3.543 (90)										
34	A	2.795 (71)	0.33 (8.4)	0.059 (1.5)	1.260 (32)	3.386 (86.0)	0.433 (11)	2.220 (56.4)		2.875 ⁰ _{-0.0012}	0.216 (5.5)	3.875 (98.43)
	B	3.858 (98)								(73.03 ⁰ _{-0.031})	(5.5)	(98.43)
	C	4.921 (125)										
42	A	4.449 (113)	0.49 (12.5)	0.059 (1.5)	2.126 (54)	4.332 (110.0)	0.433 (11)	2.220 (56.4)		2.186 ⁰ _{-0.0018}	0.335 (8.5)	4.950 (125.73)
	B	6.811 (173)								(55.52 ⁰ _{-0.046})	(8.5)	(125.73)
	C	-										

¹ For IG17, dimension S is M3*0.5 min depth 0.2 (5.1) threaded hole

IG	Imperial Shaft Option (S/F/K), Units: inches						Metric Shaft Option (X/Y/Z), Units: mm					
	D	F	GA	KA	GB	KB	D	F	GA	KA	GB	KB
17	0.1969 ⁰ _{-0.0005}	-	-	-	0.177 ⁰ _{-0.004}	0.50	5 ⁰ _{-0.013}	-	-	-	4.5 ⁰ _{-0.1}	12.7
23	0.3750 ⁰ _{-0.0005}	0.0938 ⁰ _{-0.001}	0.416 ⁰ _{-0.002}	0.5	0.340 ⁰ _{-0.004}	0.50	10 ⁰ _{-0.013}	3 ⁰ _{-0.025}	11.2 ⁰ _{-0.051}	15	9.0 ⁰ _{-0.1}	15.0
34	0.5000 ⁰ _{-0.0005}	0.1250 ⁰ _{-0.001}	0.555 ⁰ _{-0.004}	1.0	0.473 ⁰ _{-0.004}	1.00	14 ⁰ _{-0.013}	5 ⁰ _{-0.03}	16.0 ⁰ _{-0.1}	45	13.0 ⁰ _{-0.1}	45.0
42	0.7500 ⁰ _{-0.0005}	0.1875 ⁰ _{-0.0012}	0.830 ⁰ _{-0.004}	1.5	0.709 ⁰ _{-0.004}	1.50	19 ⁰ _{-0.013}	6 ⁰ _{-0.030}	21.5 ⁰ _{-0.1}	45	18.0 ⁰ _{-0.10}	45.0

HS Feedback

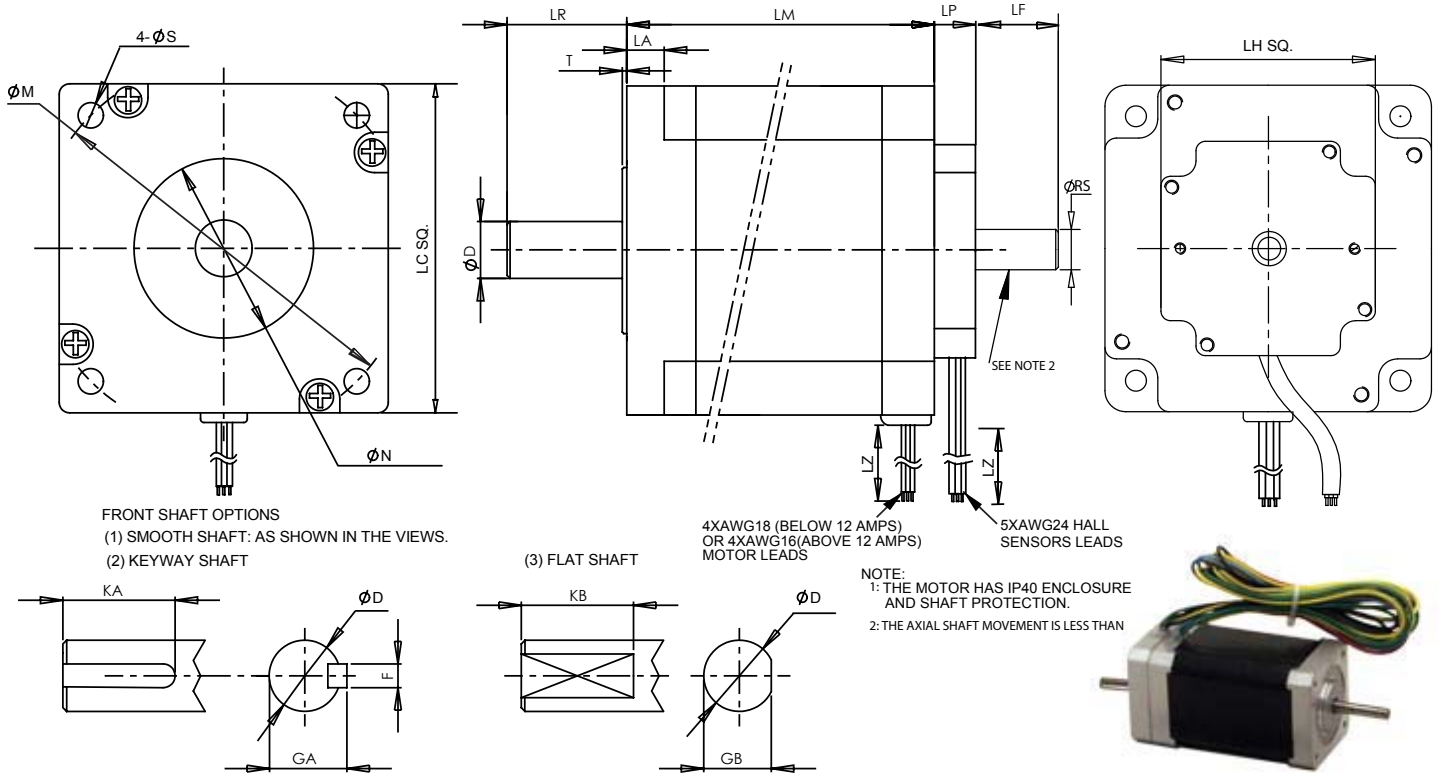

Units: Inches (mm)

IG	LM	LF	LA	T	LR	LC	LP	LH	LZ	Ø RS	N	S	M
17	A	1.496 (38)	0.472 (12)	-	0.079 (2.0)	0.945 (24)	1.665 (42.3)	0.354 (9)	1.665 (42.3)	0.1969 ⁰ _{-0.0005} (5 ⁰ _{-0.013})	0.866 ⁰ _{-0.002} (22.00 ⁰ _{-0.05})	0.118 ¹ (3.0)	1.725 (43.815)
	B	2.126 (54)											
	C	2.756 (70)											
23	A	1.890 (48)	0.650 (16.5)	0.20 (5.1)	0.060 (1.5)	0.825 (21)	2.220 (56.4)	0.433 (11)	2.220 (56.4)	0.3150 ⁰ _{-0.0005} (8 ⁰ _{-0.013})	1.500 ⁰ _{-0.002} (38.10 ⁰ _{-0.05})	0.200 (5.1)	2.625 (66.675)
	B	2.717 (69)											
	C	3.543 (90)											
34	A	2.795 (71)	0.650 (16.5)	0.33 (8.4)	0.059 (1.5)	1.260 (32)	3.386 (86.0)	0.433 (11)	2.220 (56.4)	0.3150 ⁰ _{-0.0005} (8 ⁰ _{-0.013})	2.875 ⁰ _{-0.0012} (73.03 ⁰ _{-0.031})	0.217 (5.5)	3.875 (98.425)
	B	3.858 (98)											
	C	4.921 (125)											
42	A	4.449 (113)	0.650 (16.5)	0.49 (12.5)	0.059 (1.5)	2.126 (54)	4.332 (110.0)	0.433 (11)	2.220 (56.4)	0.3150 ⁰ _{-0.0005} (8 ⁰ _{-0.013})	2.186 ⁰ _{-0.0018} (55.52 ⁰ _{-0.046})	0.335 (8.5)	4.950 (125.730)
	B	6.811 (173)											
	C	-											

¹ For IG17, dimension S is M3*0.5 min depth 0.2 (5.1) threaded hole

IG	Imperial Shaft Option (S/F/K), Units: Inches						Metric Shaft Option (X/Y/Z), Units: mm					
	D	F	GA	KA	GB	KB	D	F	GA	KA	GB	KB
17	0.1969 ⁰ _{-0.0005}	-	-	-	0.177 ⁰ _{-0.004}	0.50	5 ⁰ _{-0.013}	-	-	-	4.5 ⁰ _{-0.1}	12.7
23	0.3750 ⁰ _{-0.0005}	0.0938 ⁰ _{-0.001}	0.416 ⁰ _{-0.002}	0.50	0.340 ⁰ _{-0.004}	0.50	10 ⁰ _{-0.013}	3 ⁰ _{-0.025}	11.2 ⁰ _{-0.051}	15	9.0 ⁰ _{-0.1}	15.0
34	0.5000 ⁰ _{-0.0005}	0.1250 ⁰ _{-0.001}	0.555 ⁰ _{-0.004}	1.00	0.473 ⁰ _{-0.004}	1.00	14 ⁰ _{-0.013}	5 ⁰ _{-0.03}	16.0 ⁰ _{-0.1}	45	13.0 ⁰ _{-0.1}	45.0
42	0.7500 ⁰ _{-0.0005}	0.1875 ⁰ _{-0.0012}	0.830 ⁰ _{-0.004}	1.50	0.709 ⁰ _{-0.004}	1.50	19 ⁰ _{-0.013}	6 ⁰ _{-0.030}	21.5 ⁰ _{-0.1}	45	18.0 ⁰ _{-0.10}	45.0

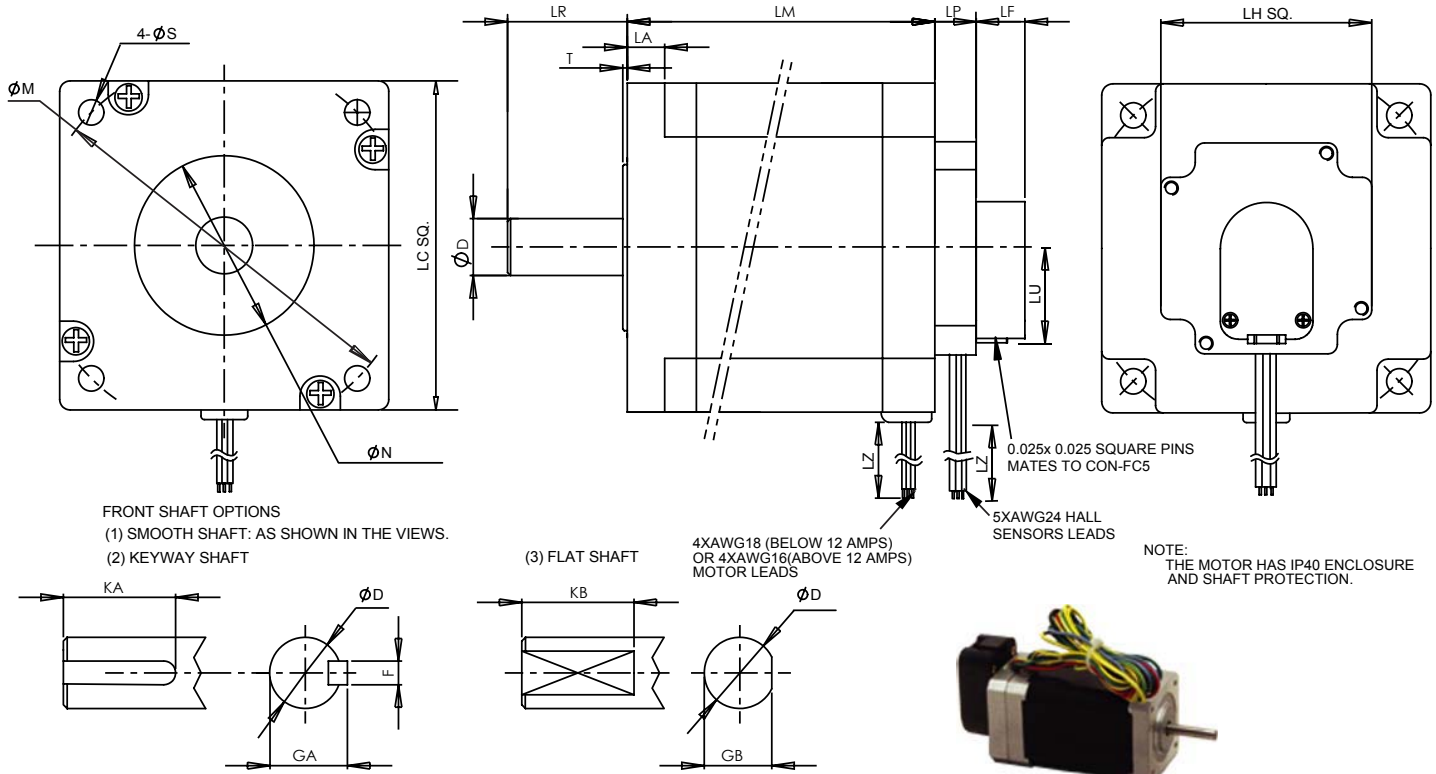

Units: Inches (mm)

IG	LM	LF	LA	T	LR	LC	LP	LH	LZ	LU	N	S	M				
17	A	1.496 (38)	0.640 (16.3)	-	0.079 (2.0)	0.945 (24)	1.665 (42.3)	0.354 (9)	1.665 (42.3)	12 (304.8)	1.251 (31.7)	0.866 ⁰ _{-0.002} (22.00 ⁰ _{-0.05})	0.118 ¹ (3.0)	1.725 (43.815)			
	B	2.126 (54)															
	C	2.756 (70)															
23	A	1.890 (48)		0.20 (5.1)	0.060 (1.5)	0.825 (21)	2.220 (56.4)	-	-			-	-	-	1.500 ⁰ _{-0.002} (38.10 ⁰ _{-0.05})	0.200 (5.1)	2.625 (66.675)
	B	2.717 (69)															
	C	3.543 (90)															
34	A	2.795 (71)		0.33 (8.4)	0.059 (1.5)	1.260 (32)	3.386 (86.0)	0.433 (11)	2.220 (56.4)			-	-	-	2.875 ⁰ _{-0.0012} (73.03 ⁰ _{-0.031})	0.217 (5.5)	3.875 (98.425)
	B	3.858 (98)															
	C	4.921 (125)															
42	A	4.449 (113)		0.49 (12.5)	0.059 (1.5)	2.126 (54)	4.332 (110.0)	-	-			-	-	-	2.186 ⁰ _{-0.0018} (55.52 ⁰ _{-0.046})	0.335 (8.5)	4.950 (125.730)
	B	6.811 (173)															
	C	-															

¹ For IG17, dimension S is M3*0.5 min depth 0.2 (5.1) threaded hole

IG	Imperial Shaft Option (S/F/K), Units: Inches						Metric Shaft Option (X/Y/Z), Units: mm					
	D	F	GA	KA	GB	KB	D	F	GA	KA	GB	KB
17	0.1969 ⁰ _{-0.0005}	-	-	-	0.177 ⁰ _{-0.004}	0.50	5 ⁰ _{-0.013}	-	-	-	4.5 ⁰ _{-0.1}	12.7
23	0.3750 ⁰ _{-0.0005}	0.0938 ⁰ _{-0.001}	0.416 ⁰ _{-0.002}	0.50	0.340 ⁰ _{-0.004}	0.50	10 ⁰ _{-0.013}	3 ⁰ _{-0.025}	11.2 ⁰ _{-0.051}	15	9.0 ⁰ _{-0.1}	15.0
34	0.5000 ⁰ _{-0.0005}	0.1250 ⁰ _{-0.001}	0.555 ⁰ _{-0.004}	1.00	0.473 ⁰ _{-0.004}	1.00	14 ⁰ _{-0.013}	5 ⁰ _{-0.08}	16.0 ⁰ _{-0.1}	45	13.0 ⁰ _{-0.1}	45.0
42	0.7500 ⁰ _{-0.0005}	0.1875 ⁰ _{-0.0012}	0.830 ⁰ _{-0.004}	1.50	0.709 ⁰ _{-0.004}	1.50	19 ⁰ _{-0.013}	6 ⁰ _{-0.030}	21.5 ⁰ _{-0.1}	45	18.0 ⁰ _{-0.10}	45.0

RNC Feedback

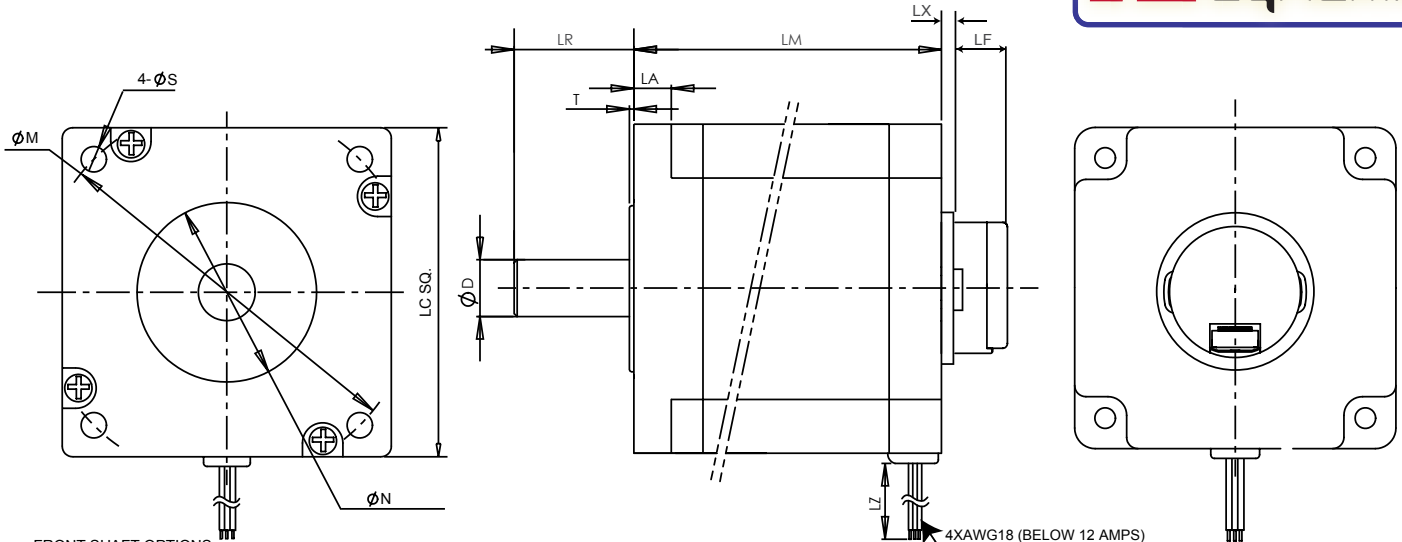

FRONT SHAFT OPTIONS

- (1) SMOOTH SHAFT: AS SHOWN IN THE VIEWS.
- (2) KEYWAY SHAFT
- (3) FLAT SHAFT

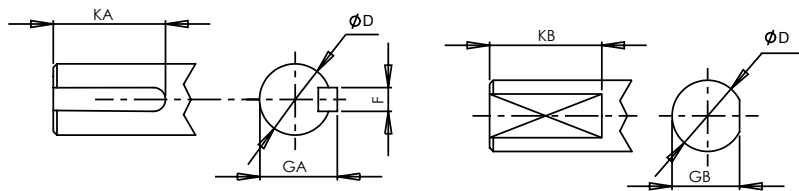

NOTE:
 (1) THE MOTOR HAS IP40 ENCLOSURE AND SHAFT PROTECTION.
 (2) ADAPTER IS USED FOR IG34 AND 42

4XAWG18 (BELOW 12 AMPS)
 OR 4XAWG16 (ABOVE 12 AMPS)
 MOTOR LEADS



Units: inches (mm)

IG	LM	LF	LA	T	LR	LC	LZ	LX	N	S	M
17	A	1.496 (38)	-	0.079 (2.0)	0.945 (24)	1.665 (42.3)	-	-	0.866 ⁰ _{-0.002} (22.00 ⁰ _{-0.05})	0.118 (3.0) ¹	1.725 (43.82)
	B	2.126 (54)									
	C	2.756 (70)									
23	A	1.890 (48)	0.55 (14.0)	0.060 (1.5)	0.825 (21)	2.220 (56.4)	12 (304.8)	-	1.500 ⁰ _{-0.002} (38.10 ⁰ _{-0.05})	0.200 (5.1)	2.625 (66.68)
	B	2.717 (69)									
	C	3.543 (90)									
34	A	2.795 (71)	0.55 (14.0)	0.059 (1.5)	1.260 (32)	3.386 (86.0)	12 (304.8)	0.15 (4)	2.875 ⁰ _{-0.0012} (73.03 ⁰ _{-0.031})	0.216 (5.5)	3.875 (98.43)
	B	3.858 (98)									
	C	4.921 (125)									
42	A	4.449 (113)	0.55 (14.0)	0.059 (1.5)	2.126 (54)	4.332 (110.0)	12 (304.8)	0.15 (4)	2.186 ⁰ _{-0.0018} (55.52 ⁰ _{-0.046})	0.335 (8.5)	4.950 (125.73)
	B	6.811 (173)									
	C	-									

¹ For IG17, dimension S is M3*0.5 min depth 0.2 (5.1) threaded hole

IG	Imperial Shaft Option (S/F/K), Units: inches						Metric Shaft Option (X/Y/Z), Units: mm						
	D	F	GA	KA	GB	KB	D	F	GA	KA	GB	KB	
17	0.1969 ⁰ _{-0.0005}	-	-	-	0.177 ⁰ _{-0.004}	0.5	5 ⁰ _{-0.013}	-	-	-	-	4.5 ⁰ _{-0.1}	12.7
23	0.3750 ⁰ _{-0.0005}	0.0938 ⁰ _{-0.001}	0.416 ⁰ _{-0.002}	0.5	0.340 ⁰ _{-0.004}	0.5	10 ⁰ _{-0.013}	3 ⁰ _{-0.025}	11.2 ⁰ _{-0.051}	15	9.0 ⁰ _{-0.1}	15.0	
34	0.5000 ⁰ _{-0.0005}	0.1250 ⁰ _{-0.001}	0.555 ⁰ _{-0.004}	1.0	0.473 ⁰ _{-0.004}	1.0	14 ⁰ _{-0.013}	5 ⁰ _{-0.03}	16.0 ⁰ _{-0.1}	45	13.0 ⁰ _{-0.1}	45.0	
42	0.7500 ⁰ _{-0.0005}	0.1875 ⁰ _{-0.0012}	0.830 ⁰ _{-0.004}	1.5	0.709 ⁰ _{-0.004}	1.5	19 ⁰ _{-0.013}	6 ⁰ _{-0.030}	21.5 ⁰ _{-0.1}	45	18.0 ⁰ _{-0.10}	45.0	

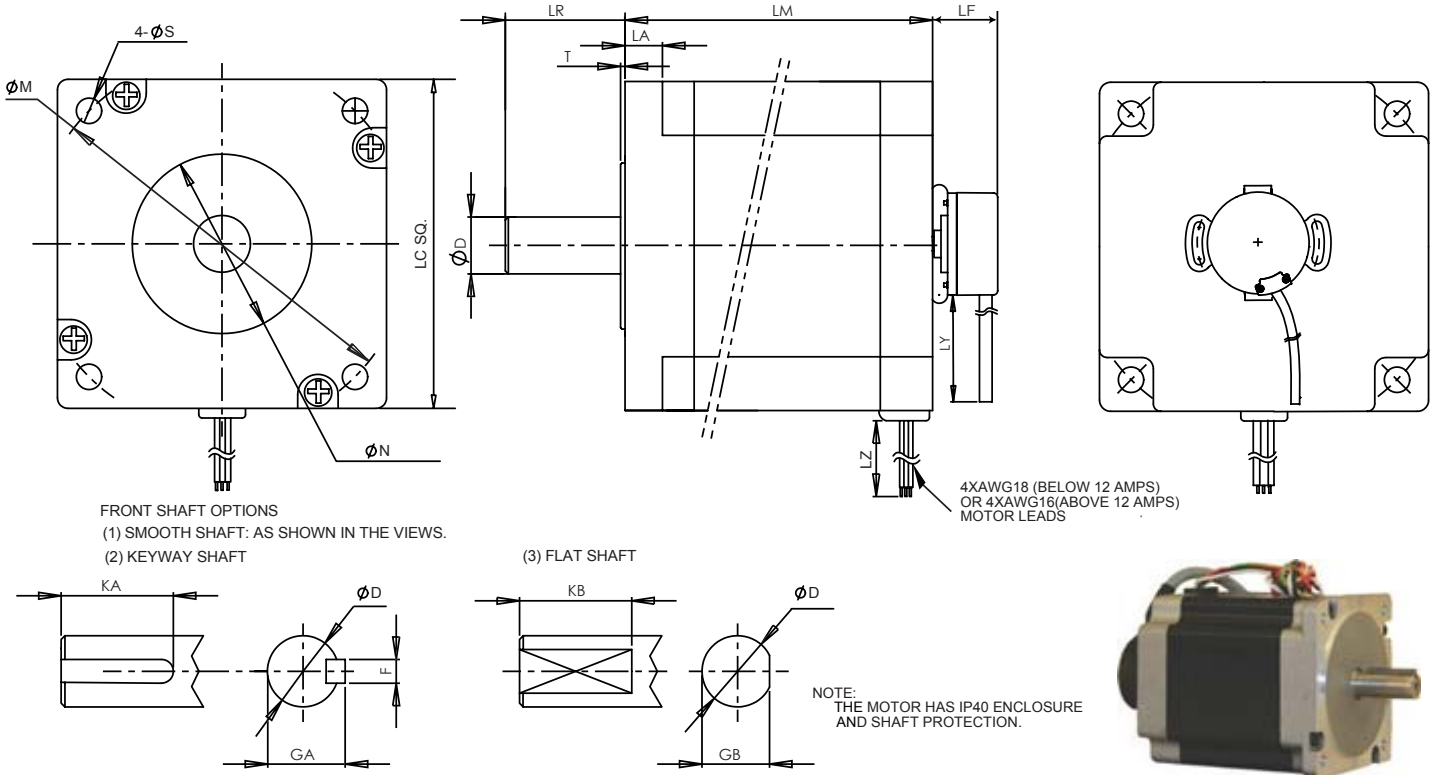

Units: Inches (mm)

IG	LM	LF	LA	T	LR	LC	LP	LZ	LY	N	S	M
17	A	1.496 (38)	-	0.079 (2.0)	0.945 (24)	1.665 (42.3)	0.354 (9)	12 (304.8)	12 (304.8)	0.866 ⁰ _{-0.002}	0.118 (3.0) ¹	1.725 (43.815)
	B	2.126 (54)								(22.00 ⁰ _{-0.05})		
	C	2.756 (70)										
23	A	1.890 (48)	1.00 (25.4)	0.060 (1.5)	0.825 (21)	2.220 (56.4)	0.433 (11)	12 (304.8)	12 (304.8)	1.500 ⁰ _{-0.002}	0.200 (5.1)	2.625 (66.675)
	B	2.717 (69)								(38.10 ⁰ _{-0.05})		
	C	3.543 (90)										
34	A	2.795 (71)	1.00 (25.4)	0.059 (1.5)	1.260 (32)	3.386 (86.0)	0.433 (11)	12 (304.8)	12 (304.8)	2.875 ⁰ _{-0.0012}	0.217 (5.5)	3.875 (98.425)
	B	3.858 (98)								(73.03 ⁰ _{-0.031})		
	C	4.921 (125)										
42	A	4.449 (113)	1.00 (25.4)	0.059 (1.5)	2.126 (54)	4.332 (110.0)	0.433 (11)	12 (304.8)	12 (304.8)	2.186 ⁰ _{-0.0018}	0.335 (8.5)	4.950 (125.730)
	B	6.811 (173)								(55.52 ⁰ _{-0.046})		
	C	-										

¹ For IG17, dimension S is M3*0.5 min depth 0.2 (5.1) threaded hole

IG	Imperial Shaft Option (S/F/K), Units: Inches						Metric Shaft Option (X/Y/Z), Units: mm					
	D	F	GA	KA	GB	KB	D	F	GA	KA	GB	KB
17	0.1969 ⁰ _{-0.0005}	-	-	-	0.177 ⁰ _{-0.004}	0.50	5 ⁰ _{-0.013}	-	-	-	4.5 ⁰ _{-0.1}	12.7
23	0.3750 ⁰ _{-0.0005}	0.0938 ⁰ _{-0.001}	0.416 ⁰ _{-0.002}	0.50	0.340 ⁰ _{-0.004}	0.50	10 ⁰ _{-0.013}	3 ⁰ _{-0.025}	11.2 ⁰ _{-0.051}	15	9.0 ⁰ _{-0.1}	15.0
34	0.5000 ⁰ _{-0.0005}	0.1250 ⁰ _{-0.001}	0.555 ⁰ _{-0.004}	1.00	0.473 ⁰ _{-0.004}	1.00	14 ⁰ _{-0.013}	5 ⁰ _{-0.03}	16.0 ⁰ _{-0.1}	45	13.0 ⁰ _{-0.1}	45.0
42	0.7500 ⁰ _{-0.0005}	0.1875 ⁰ _{-0.0012}	0.830 ⁰ _{-0.004}	1.50	0.709 ⁰ _{-0.004}	1.50	19 ⁰ _{-0.013}	6 ⁰ _{-0.030}	21.5 ⁰ _{-0.1}	45	18.0 ⁰ _{-0.10}	45.0

QDC Feedback

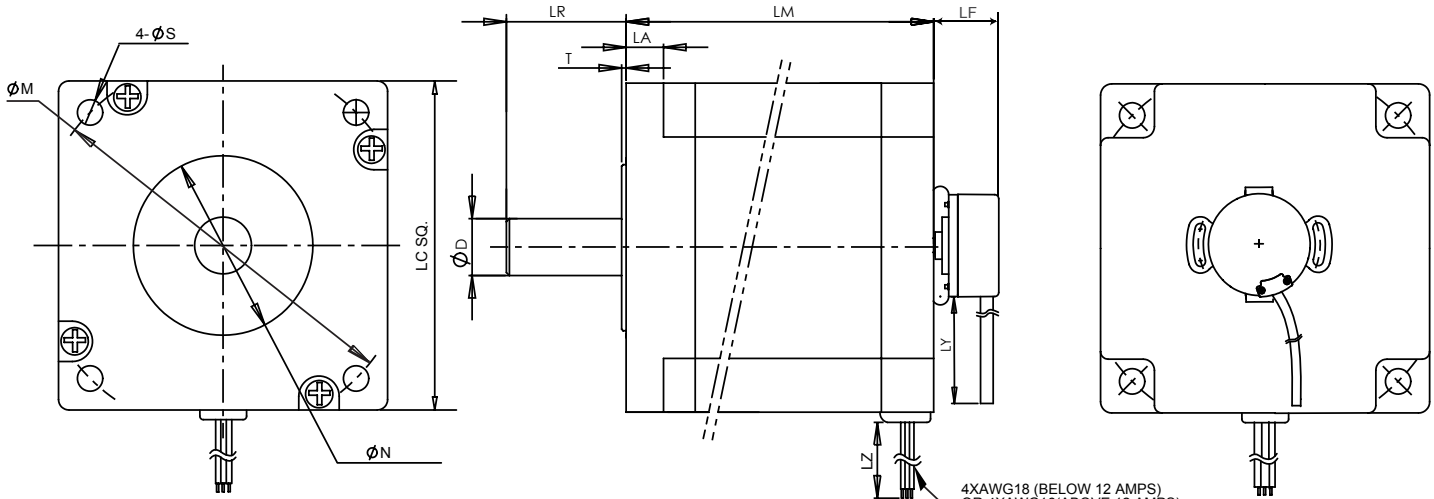

FRONT SHAFT OPTIONS
 (1) SMOOTH SHAFT: AS SHOWN IN THE VIEWS.
 (2) KEYWAY SHAFT

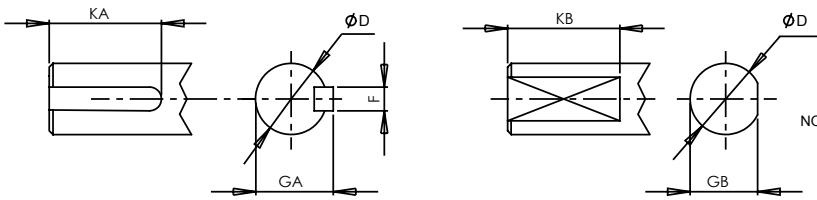

NOTE:
 THE MOTOR HAS IP40 ENCLOSURE
 AND SHAFT PROTECTION.



Units: Inches (mm)

IG	LM	LF	LA	T	LR	LC	LZ	LY	N	S	M	
17	A	1.496 (38)	-	0.079 (2.0)	0.945 (24)	1.665 (42.3)	-	-	0.866 ⁰ _{-0.002} (22.00 ⁰ _{-0.05})	0.118 (3.0) ¹	1.725 (43.815)	
	B	2.126 (54)										
	C	2.756 (70)										
23	A	1.890 (48)	1.00 (25.4)	0.20 (5.1)	0.060 (1.5)	0.825 (21)	2.220 (56.4)	12 (304.8)	12 (304.8)	1.500 ⁰ _{-0.002} (38.10 ⁰ _{-0.05})	0.200 (5.1)	2.625 (66.675)
	B	2.717 (69)										
	C	3.543 (90)										
34	A	2.795 (71)	0.33 (8.4)	0.059 (1.5)	1.260 (32)	3.386 (86.0)	-	-	2.875 ⁰ _{-0.0012} (73.03 ⁰ _{-0.031})	0.217 (5.5)	3.875 (98.425)	
	B	3.858 (98)										
	C	4.921 (125)										
42	A	4.449 (113)	0.49 (12.5)	0.059 (1.5)	2.126 (54)	4.332 (110.0)	-	-	2.186 ⁰ _{-0.0018} (55.52 ⁰ _{-0.046})	0.335 (8.5)	4.950 (125.730)	
	B	6.811 (173)										
	C	-										

¹ For IG17, dimension S is M3*0.5 min depth 0.2 (5.1) threaded hole

IG	Imperial Shaft Option (S/F/K), Units: Inches						Metric Shaft Option (X/Y/Z), Units: mm					
	D	F	GA	KA	GB	KB	D	F	GA	KA	GB	KB
17	0.1969 ⁰ _{-0.0005}	-	-	-	0.177 ⁰ _{-0.004}	0.50	5 ⁰ _{-0.013}	-	-	-	4.5 ⁰ _{-0.1}	12.7
23	0.3750 ⁰ _{-0.0005}	0.0938 ⁰ _{-0.001}	0.416 ⁰ _{-0.002}	0.50	0.340 ⁰ _{-0.004}	0.50	10 ⁰ _{-0.013}	3 ⁰ _{-0.025}	11.2 ⁰ _{-0.051}	15	9.0 ⁰ _{-0.1}	15.0
34	0.5000 ⁰ _{-0.0005}	0.1250 ⁰ _{-0.001}	0.555 ⁰ _{-0.004}	1.00	0.473 ⁰ _{-0.004}	1.00	14 ⁰ _{-0.013}	5 ⁰ _{-0.03}	16.0 ⁰ _{-0.1}	45	13.0 ⁰ _{-0.1}	45.0
42	0.7500 ⁰ _{-0.0005}	0.1875 ⁰ _{-0.0012}	0.830 ⁰ _{-0.004}	1.50	0.709 ⁰ _{-0.004}	1.50	19 ⁰ _{-0.013}	6 ⁰ _{-0.030}	21.5 ⁰ _{-0.1}	45	18.0 ⁰ _{-0.10}	45.0

Hall Sensor Electrical Data

Parameter	Values
Supply Voltage	Min. 4.5 V Max. 24 V
Supply Current	Max. 11.3 mA
Output Current	Max. 20 mA
Rise Time	Typ. 0.5 μ s Max. 1.5 μ s
Fall Time	Typ. 0.2 μ s Max. 1.5 μ s
Response Time	Typ. 4.0 μ s Max. 5 μ s
Operating Temperature	-40°C to 125°C (-40°F to 257°F)
Storage Temperature	-55°C to 165°C (-67°F to 329°F)

Hall Sensor Wiring Diagram

Wire Color	Function
RED	+Vcc
YEL	HALL U
GRN	HALL V
BLU	HALL W
BLK	GND

Hall Sensor Output Waveforms

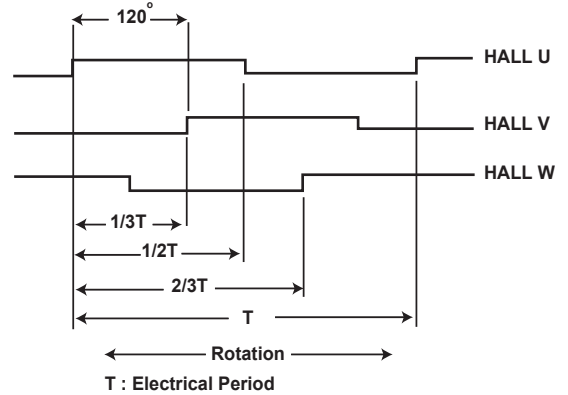

US Digital Encoder Data

Parameter	Values
Input Voltage, Vcc	Typ. +5VDC Min. 4.5 VDC Max. 5.5 VDC
Input Current Requirement	Typ. 57 mA Min. 30 mA Max. 85 mA
Output Voltage	Min. -0.5 VDC Max. Vcc
Output Current Per Channel	Min. -8.0 mA Max. 8.0 mA
Output Data	Incremental - Two square waves in quadrature with channel A leading B for clockwise shaft rotation as viewed from the encoder mounting face
Output Format	TTL level output
Frequency Response	100 kHz
Minimum Edge Separation	45° electrical angle
Maximum Speed	6000 rpm
Operating Temperature	-40°C to 100°C
Storage Temperature	-15°C to 85°C
Available line counts	32 to 1250 ppr

E5S Encoder Wiring Diagram

Pin No.	Function
1	GND
2	INDEX
3	CH A
4	+5VDC
5	CH B

Encoder Output Waveforms

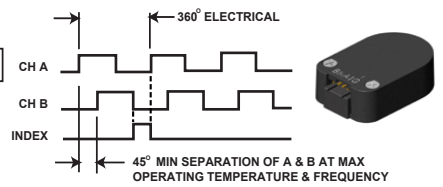

Mating Connector: CON-FC5-22AWG



E5D Encoder Wiring Diagram

Wire #	Function
1	Ground
2	Ground
3	Index-
4	Index+
5	A- channel
6	A+ channel
7	+5VDC power
8	+5VDC power
9	B- channel
10	B+ channel

Encoder Output Waveforms

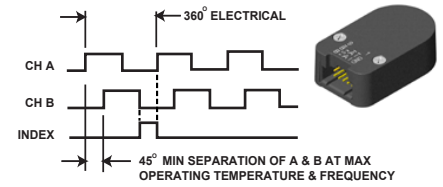

Mating Connector: CON-FC10

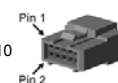

Renco Encoder Data

Parameter	Values
Input Voltage	5 VDC \pm 10% Single Supply
Input Current Requirement	175 mA
Output Data	Line driver
Output Format	Square wave two channel quadrature with index & commutation signals
Frequency Response	500 kHz
Minimum Edge Separation	45° electrical angle
Commutation Format	Three commutation channels, 4 cycles/360 electrical angle for eight poles
Termination	15 pins JAE P/N F1.W15P.HF interface
Operating Temperature	-30°C to 115°C
Storage Temperature	-40°C to 125°C
Available line counts	250, 256, 500, 512, 1000, 1024, 2000, 2048, 4000, 4096, 8000, 8192 ppr

Encoder Wiring Diagram

Function	Color
CH A	BRN with BLK
CH A-	BLK with BRN
CH B	BLU with BLK
CH B-	BLK with BLU
INDEX	ORN with BLK
INDEX-	BLK with ORN
CH U	YEL with BLK
CH U-	BLK with YEL
CH V	GRN with BLK
CH V-	BLK with GRN
CH W	RED with BLK
CH W-	BLK with RED
+5VDC	WHT with BLK
GND	BLK with WHT
Thermistor 1	RED with WHT
Thermistor 2	WHT with RED
SHIELD	SHIELD

Encoder Output Waveforms

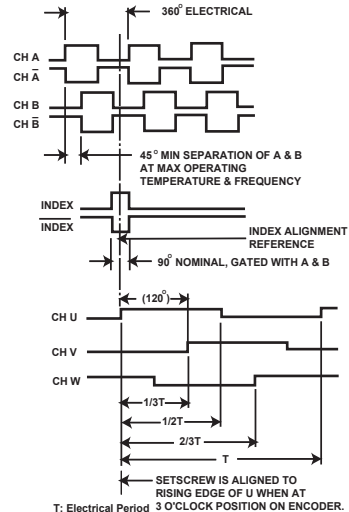

Mating Connector: JAE P/N F1-W15P-HF



Encoder Products and Quantum Encoder Data

Parameter	Values
Input Voltage	5 VDC \pm 10% Fixed Voltage
Input Current Requirement	100 mA max (65 mA typical) with no output load
Output Data	Incremental - Two square waves in quadrature with channel A leading B for clockwise shaft rotation as viewed from the encoder mounting face
Output Format	Line Driver - 20mA max per channel (meets RS 422 at 5 VDC)
Frequency Response	200 kHz standard, 300 kHz optional
Minimum Edge Separation	67.5° electrical
Commutation Format	8 poles
Commutation Accuracy	1° mechanical
Maximum Speed	8000 RPM
Termination	18" cable (foil and braid shield, 24 AWG conductors non-commutated, 28 AWG commutated).
Operating Temperature	-20 to +85° C standard
Storage Temperature	-25 to +85° C
Encoder Products Available line counts	200, 250, 256, 300, 315, 360, 400, 500, 512, 580, 600, 800, 1000, 1024, 1200, 1250, 2000, 2048, 2500, 2540
Quantum Available line counts	200, 250, 256, 500, 512, 600, 1000, 1024, 1250, 2000, 2048, 2500, 4096, 5000

Encoder Products Wiring Diagram

Wire Color	Function
BRN	CH A
YEL	CH A-
RED	CH B
GRN	CH B-
ORN	INDEX
BLU	INDEX-
VIO	CH U
GRY	CH U-
PNK	CH V
TAN	CH V-
RED/GRN	CH W
RED/YEL	CH W-
WHT	+5VDC
BLK	GND
SHIELD	SHIELD



Encoder Products Output Waveforms

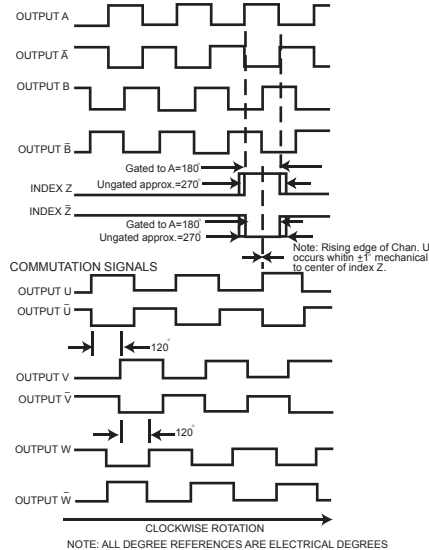

Quantum Devices Wiring Diagram

Wire Color	Function
Red	+VDC
Black	Common
Brown	Output A
White	Output A'
Blue	Output B
Green	Output B'
Orange	Output Z
Yellow	Output Z'
Violet	Output U
Gray	Output U'
Brown/White	Output V
Red/White	Output V'
Orange/White	Output W
Yellow/White	Output W'
Black/White	Case Ground
Drain Wire	Cable Shield



Quantum Devices Output Waveforms

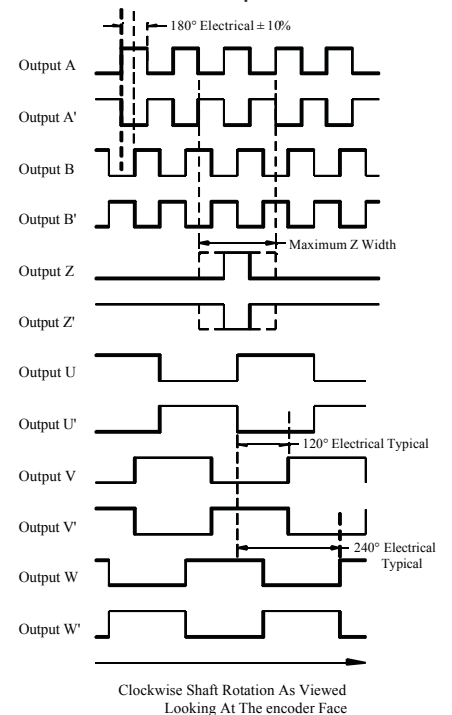

Motor Wiring Diagram for F Housing Option

Wire Color	Function
YEL	PHASE U
GRN	PHASE V
BLU	PHASE W
GRN/YEL	PE