

DigiDrive
INFORMATION MANUAL
2000 / 4000

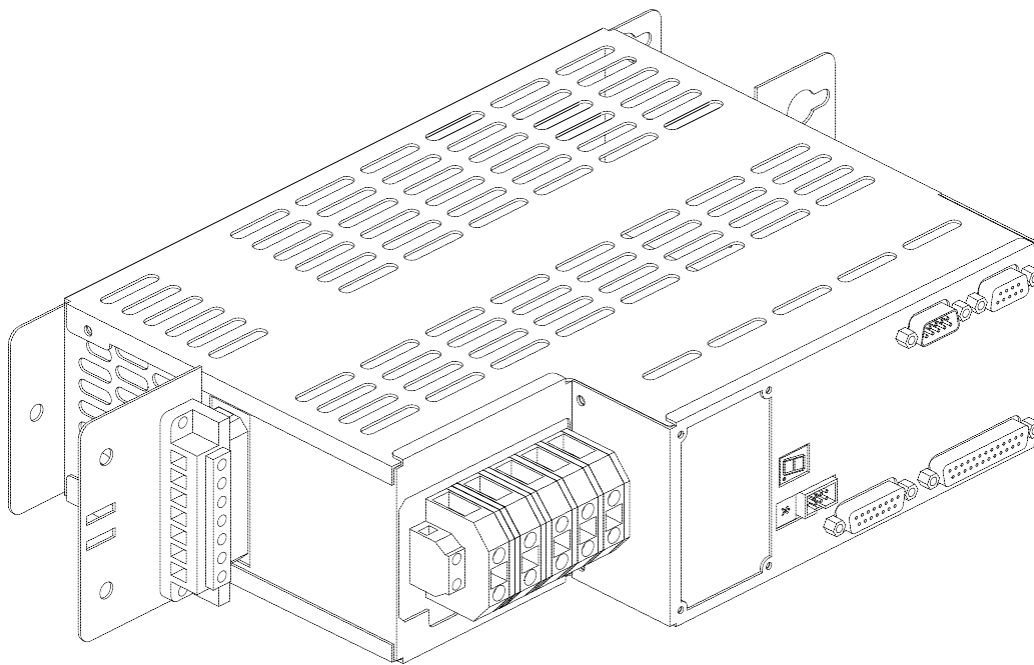

Servo Dynamics Corp.

28231 Avenue Crocker, Ste 10

Valencia, CA. 91355

PH: (818) 700-8600

www.servodynamics.com



Contents

CHAPTER A DESCRIPTION AND TECHNICAL DATA	6
1. INTRODUCTION	6
2. DESCRIPTION	6
3. TECHNICAL DATA	7
3.1 GENERAL DATA FOR ALL TYPES	7
3.2 ELECTRICAL DATA	8
3.3 SMALL DRIVE OUTLINES	10
3.4 MEDIUM DRIVE OUTLINES	11
3.5 LARGE DRIVE OUTLINES	12
3.6 SMALL AND MEDIUM WITH SPECIAL CLAMP TYPE PHOENIX (OPTION)	13
3.7 MOTORS	14
3.8 POSITION FEEDBACK	14
4. FUSES	15
5. OPTION LIST	15
6. ADD-ON BOARDS	16
7. EXTERNAL MODULES	17



CHAPTER B USER UTILITIES **19**

1. DOS USERS	19
1.1 FPRGU.EXE : FLASH PROGRAMMING USER	19
1.2 2000U.EXE : 2000 USER	20
2. WINDOWS USERS	21
2.1 2000WU.EXE : 2000 WINDOWS USER	21
3. SERIAL LINK	23
3.1 DIALOGUE PROTOCOL	23
3.2 DIALOGUE EXAMPLES	25

CHAPTER C DRIVE PARAMETERS **26**

1. PARAMETERS DESCRIPTION	26
1.1 GLOBAL LIST OF PARAMETERS	27
1.2 SCOPE PARAMETERS	34

CHAPTER D SETTING TO WORK **35**

1. WIRING	35
1.1 CABLE LENGTHS AND CROSS-SECTIONS	35
1.2 GLOBAL WIRING PLAN	36
1.3 CONTROL UNIT WIRING	37
1.3.1 XRESOLVER	38
1.3.2 XCOMMAND	39
1.3.3 XENCODER	40
1.3.4 XSERIAL 232 AND XSERIAL 485	41
1.3.5 AXIS SELECTOR	43



1.4 XMOTOR CONNECTOR	43
1.4.1 DETERMINING THE MOTOR PHASES (WITHOUT DRIVE)	44
2. DISPLAY INDICATIONS	45
2.1 ALARMS	46
2.2 WARNINGS	47
3. PARAMETERS SETTINGS	48
3.1 MOTOR PARAMETERS	48
3.1.1 EXAMPLE OF MOTOR PARAMETERS	50
3.2 INSTALLATION PARAMETERS	51
3.2.1 ENCODER CONFIGURATION	52
3.2.2 END-SWITCH CONFIGURATION	54
3.2.3 SSI CONFIGURATION (OPTION)	54
3.2.4 GENERAL CONFIGURATION	55
3.3 REGULATION PARAMETERS	57
3.3.1 CONFIGURATION	57
3.3.2 CURRENT LOOP	58
3.3.3 SPEED LOOP	60
4. HOW TO SET THE PARAMETERS	61
4.1 HOW TO SET THE RESOLVER SHIFT ANGLE PARAMETER	63
4.2 HOW TO SET THE CURRENT LOOP PARAMETERS	65
4.3 HOW TO SET THE SPEED LOOP PARAMETERS	67
5. TROUBLE SHOOTING	69
CHAPTER E ASYNCHRONOUS MOTOR	73
<hr/>	
1. CHANGE OF MOTOR AND FEEDBACK TYPE	73
2. SPECIAL PARAMETERS FOR ASYNCHRONOUS MOTORS	73



2.1 FIELD WEAKENING	74
2.2 ASYNCHRONOUS ALARM	74
2.3 FEEDBACK TYPE	75
2.3.1 RESOLVER FEEDBACK	75
2.3.2 ENCODER FEEDBACK	75



CHAPTER A DESCRIPTION AND TECHNICAL DATA

1. Introduction

The servo-amplifiers series 2000 and 4000 are intended for the control of 3 phases brushless servo-motors equipped with resolver and asynchronous servo-motors equipped with resolver or encoder.

To avoid any confusion, the motors regulated by the series 2000 and 4000 servo-amplifiers should have the following characteristics:

- Rotor constructed with permanent magnets or winding cage arranged in 1, 2, 3, 4, 5 or 6 pole pairs, without commutator.
- Stator constructed with 3 windings connected in star or delta.
- Brushless motors : electronic commutation is only effected by means of a **speed one** resolver (motors with Hall effect sensors and tachogenerator are not suitable).
- Asynchronous motors : electronic commutation is only effected by means of a **speed one** resolver or an **incremental encoder**.

The servo-amplifier series 2000 and 4000 are fully digital. High-performance torque, speed and positioning control fulfils all requirements for rapid response and control accuracy.

Digital control allows comprehensive diagnostics, motor parameters tuning, data and fault logging, etc.. using a PC based user program.

A wide range of firmware assures that it will meet the requirements of practically any application.

2. Description

The particular features of the servo-amplifiers series 2000 and 4000 are described there under:

Power supply

- Single-Axis unit incorporating a braking module for connection to 3 phase power. The drive also can be run from a common DC-bus voltage.



- Series 2000: 230V three-phase power source.
- Series 4000: Direct 400V three-phase main supply.
- Option: Internal filters in power source reducing noise emission.

Power driver

- Galvanic isolation between control and power electronics.
- IGBT output stage.
- Digital PWM current loop provides very low ripple motor currents and high motor efficiency.

Digital controller

- Full-digital servo-amplifier for Brushless motor with resolver.
- Software updates are fully programmable through serial link RS232 or RS485.
- Accepts customised network *INTERFACE* boards.
- Energy managing system for fan-cooling.
- Multi loop control (torque and speed).
- Sinusoidal current output ensures smooth torque and optimal performance at low speed.
- 7 segment status indicator for diagnostic display.

User's inputs

- Analogue speed or current input command +/- 10V or digital input command.
- RS232 serial port and RS485 serial port for multi axis controller system.
- Limit switches for overrun protection in both directions.
- External power supply to the Control and Interface boards to keep position data and alarms in case of main power supply interruption.

User's outputs

- Incremental encoder output simulation with adjustable resolution from 1 to 2048 ppr and adjustable marker pulse. Differential line driver outputs.
- Ready relay contact.

Protections

- Protection and rugged construction for use in adverse conditions.
- Power stage fully protected against short-circuit and over-temperature.
- Motor protection by I²t limitation.
- Detection of resolver fault, motor wiring failure, motor overheating.

3. Technical data

3.1 General data for all types

Description	Unit	Series 2000	Series 4000
-------------	------	-------------	-------------



Supply Voltage	VAC	3x230 +10% -20%	3x400 +10% -20%
Supply frequency	Hz	45 to 65	
Operating temperature range	° C	0 to 60	
Operating temperature range at full power (from 45°C, reduce output current by 2% / °C to 60°C)	° C	0 to 45	
Storage temperature range	°C	-25 to +55	
PWM chopper frequency	kHz	7.5	
Differential input reference	V	+ 10 to -10	
Speed control range		1/32768	
Speed loop bandwidth	Hz	max. 150	
Current loop bandwidth	Hz	max. 2000	
Max. output voltage to motor	V	3 x 220	3 x 390
Output frequency to motor	Hz	0 to 500	
Incremental encoder simulation	ppr	1 to 2048	
Theoretical max. speed for motor with resolver "speed one"	rpm	7500	
ON-Switching threshold of brake module	VDC	385	670
OFF-Switching threshold of brake module	VDC	380	660
ON-Trip threshold of overvoltage	VDC	410	710
OFF-Trip threshold of overvoltage	VDC	400	690
OFF-Trip threshold of undervoltage	VDC	230	395
ON-Trip threshold of undervoltage	VDC	220	380
Serial link	Standard baud rate	Bd.	9600
	Transmission		Full duplex
	Format		1start bit, 8 data bits, no parity, 1 stop bit
International Protection		IP20	
Indicative weight	kg	Small: 3.2, Medium: 6.1, Large:10.5	

3.2 Electrical data

Drive Size	Drive Model Number	Rated rms Current (I rms)	Rated pk. Current (I peak rated)	Max. rms Current (I rms max)	Max. peak Current (I peak max)	Rated power (P rated)	Max. Power (P max)
------------	--------------------	---------------------------	----------------------------------	------------------------------	--------------------------------	-----------------------	--------------------



		(A)	(A)	(A)	(A)	(kW)	(kW)
Small	DSSA 0510-34	5	7	10	14	2	4
	DSSA 1020-34	10	14	20	28	4	8
	DSSA 1836-34	18	25	36	50	7	14
	DSSA 0306-56	3	4	6	8.5	2	4
	DSSA 0510-56	5	7	10	14	3.5	7
	DSSA 0918-56	9	13	18	25	6	12
Medium	DSSA 2040-56	20	28	40	56	13.5	27
Large	DSSA 2040-56	20	28	40	56	13.5	27
	DSSA 3060-56	30	42	60	84	20	40

Note:

$$I_{rms} = I_{peak} / 1,41$$

$$V_{rms} = 220V \text{ or } 390V$$

$$P = 1,73 \times I_{rms} \times V_{rms} \quad \text{or} \quad P = 3 \times I_{rms}/\text{phase} \times V_{rms}/\text{phase}$$

Braking power :

Drive Size	Drive Model Number	R braking (Ω)	Peak braking Power (W)	Max. continuous braking power (W)	Surge energy ($\Delta T=300K$) (J)
Small	DSSA 0510-34	39	3'800	150	1'800
	DSSA 1020-34	39	3'800	150	1'800
	DSSA 1836-34	39	3'800	150	1'800
	DSSA 0306-56	56	8'000	250	2'600
	DSSA 0510-56	56	8'000	250	2'600
	DSSA 0918-56	56	8'000	250	2'600
Medium	DSSA 2040-56	20	22'000	500	5'200
Large	DSSA 2040-56	11	41'000	1'000	21'000
	DSSA 3060-56	8	56'000	1'000	24'000

The surge energy rating is the maximum permitted dynamic brake application from cold. To a first approximation, heat is then removed at the rate given by the continuous power figure : thus about 20 seconds interval must be allowed between full energy stops.



3.3 Small drive outlines

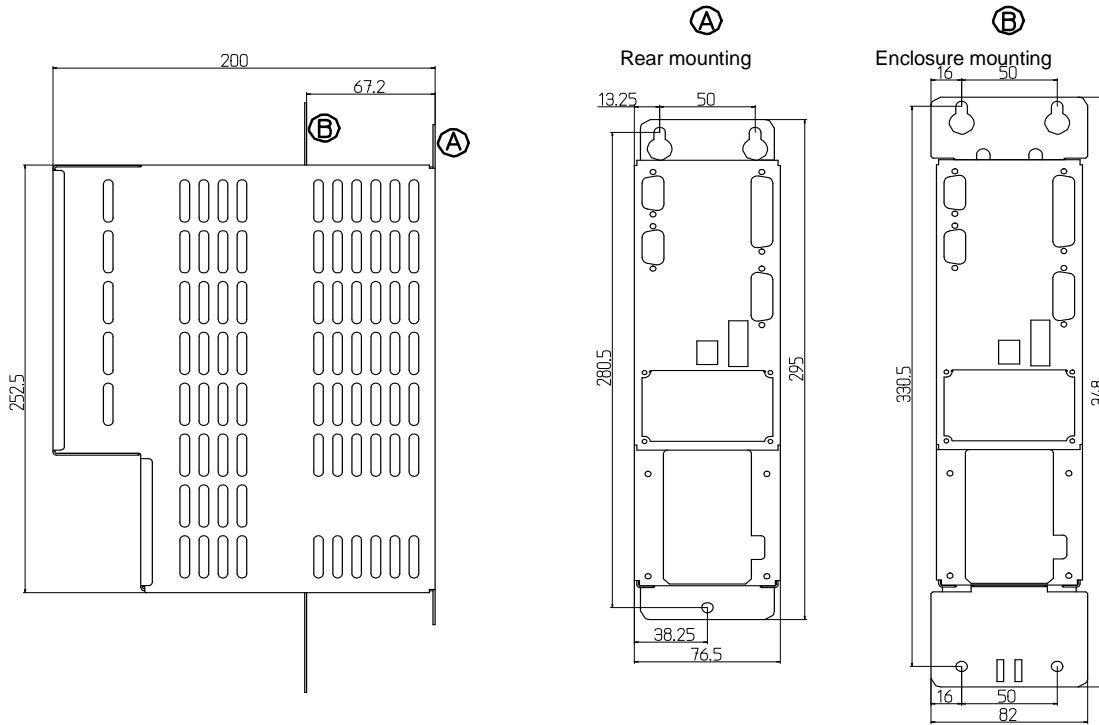

Installation, drill and cut out plan :

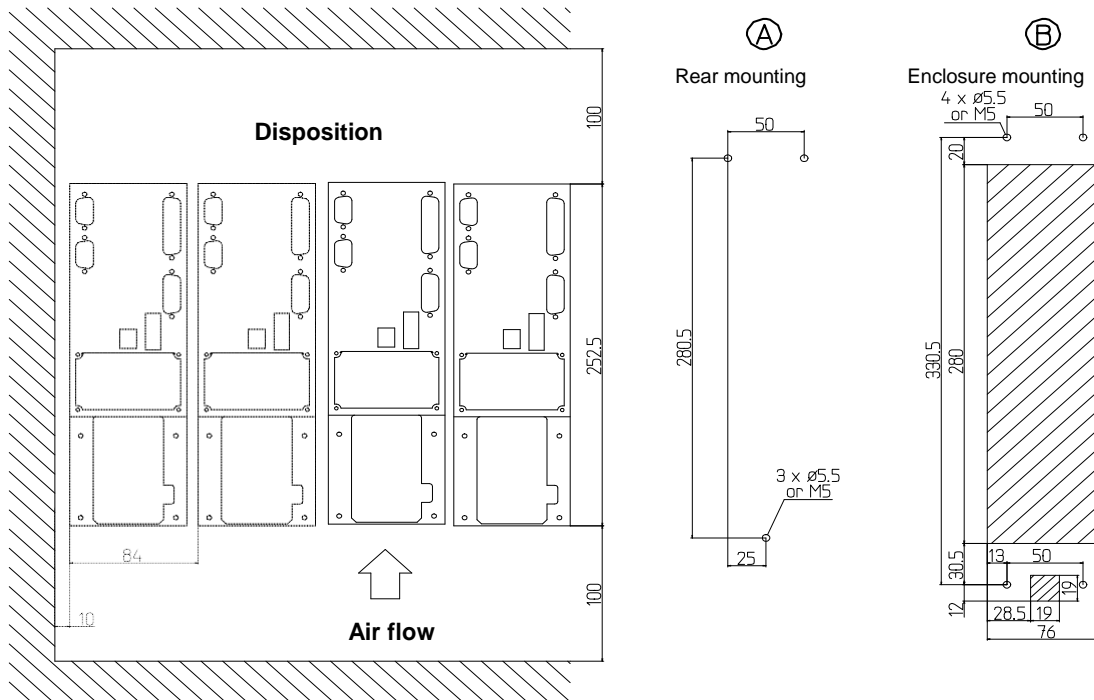



3.4 MEDIUM DRIVE OUTLINE

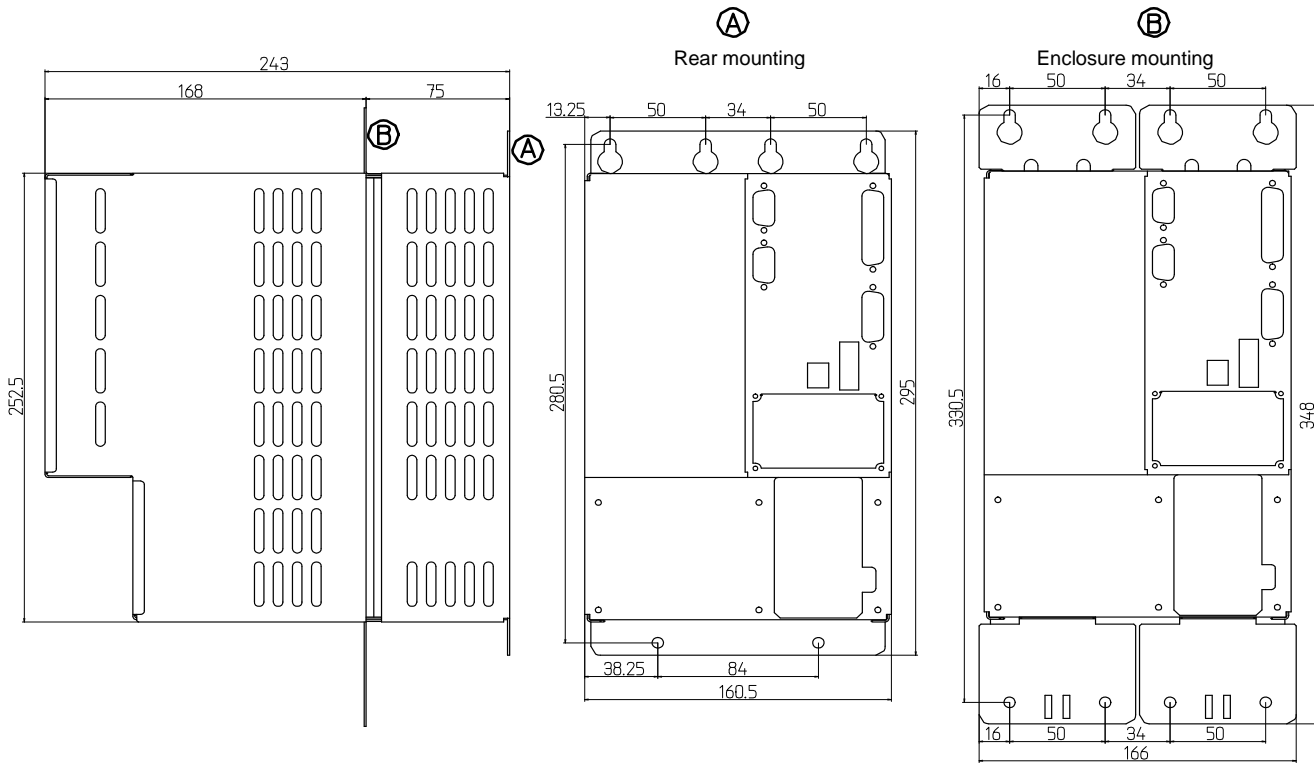

Installation, drill and cutout plan :

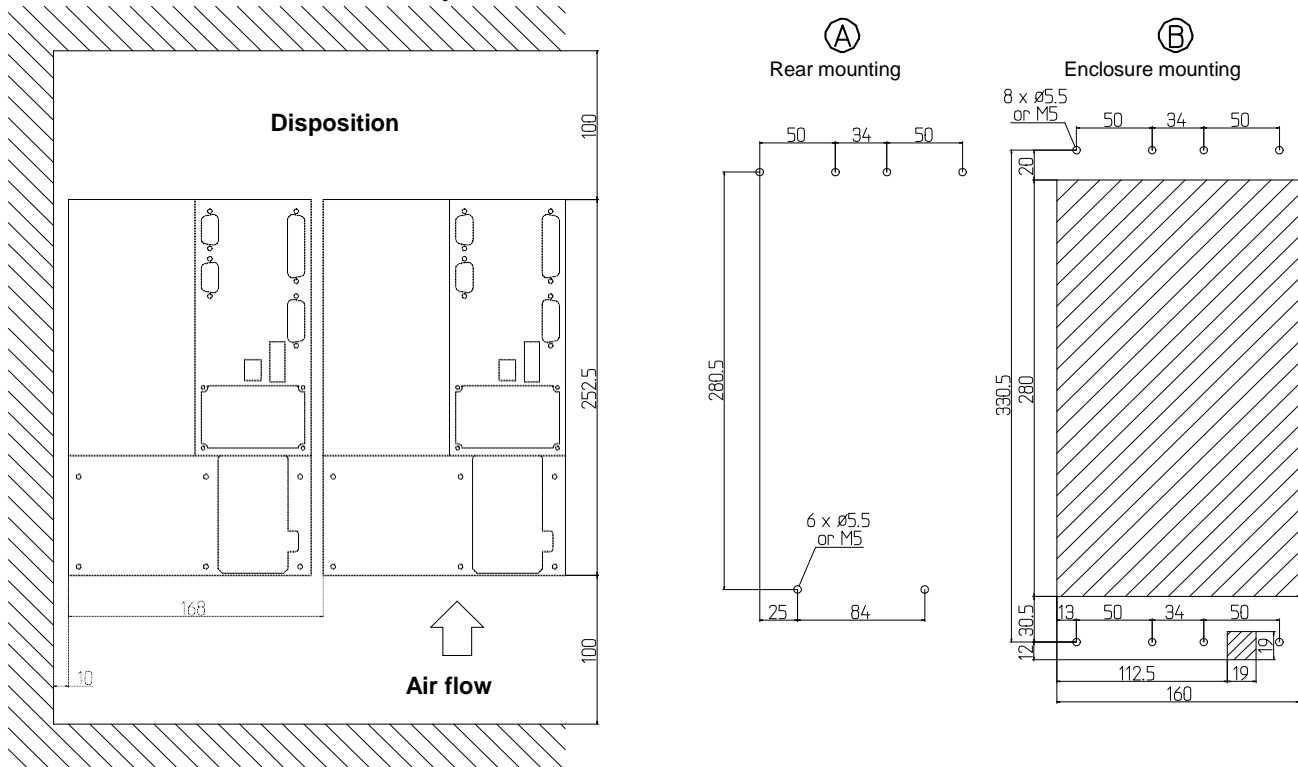



3.5 LARGE DRIVE OUTLINE

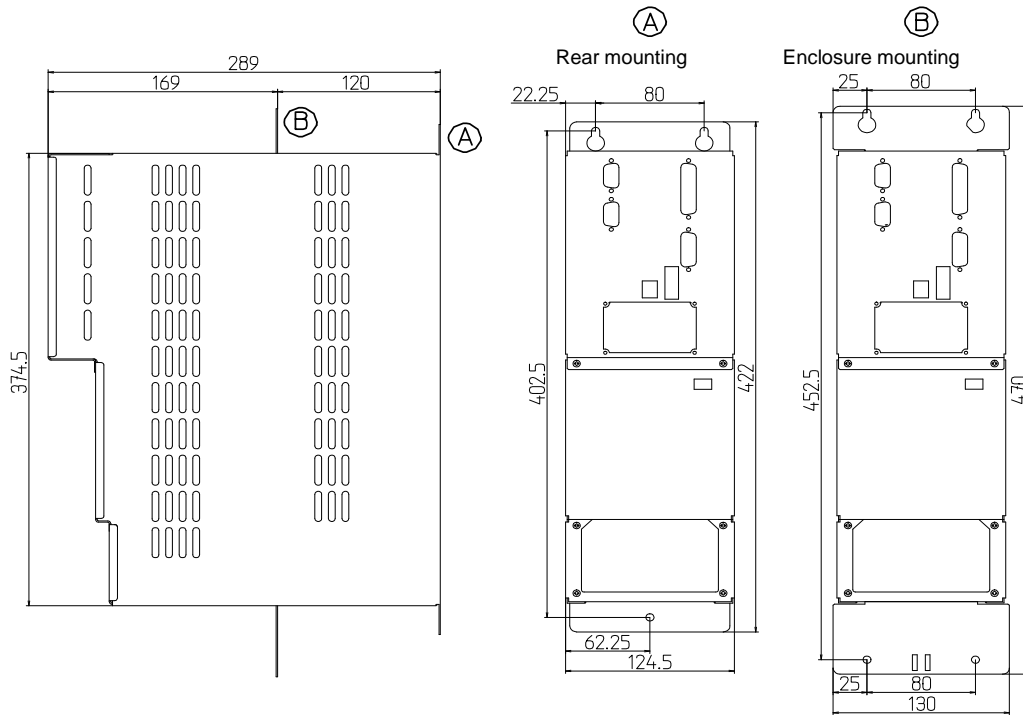

Installation, drill and cutout plan :

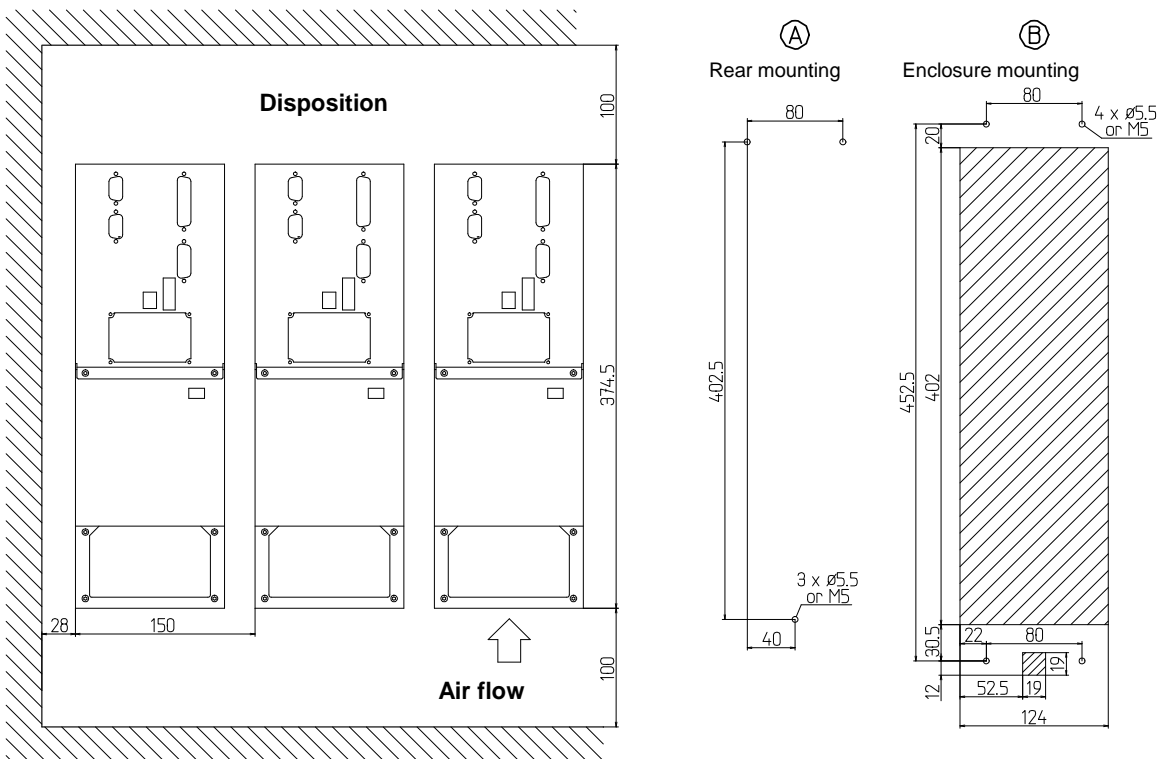



3.6 Small and Medium with special clamp type Phoenix (option)

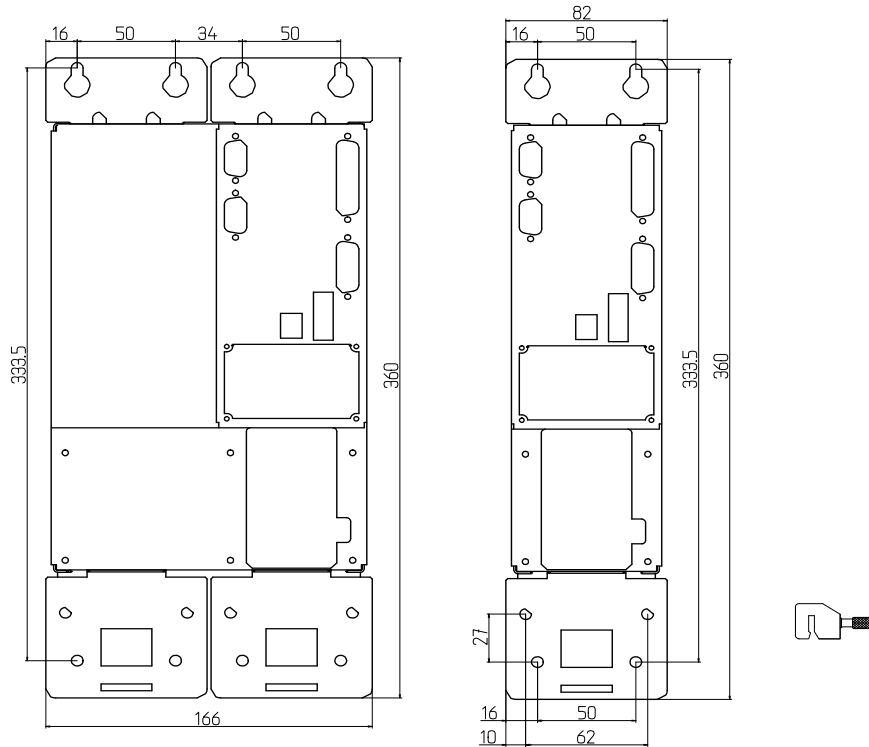

Drill and cutout plan for enclosure mounting :

Phoenix clamp type SK8

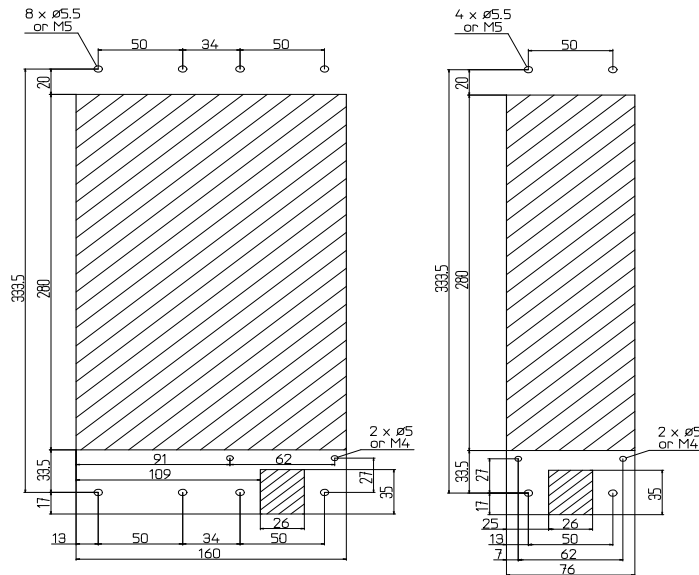



3.7 Motors

D Brushless 3 phases servo-motors

D Asynchronous, 3 phases motors

3.8 Position feedback

D Resolver :

Characteristics :

- Speed One (1 sine period and 1 cosine period per revolution)
- Ratio 0.5
- Reference frequency : 5..10 kHz

D Incremental encoder for asynchronous motor only.

D Absolute encoder Stegmann SinCos (HIPERFACE compatible).

D Absolute encoder Stegmann SinCoder (HIPERFACE compatible).



4. Fuses

The following are the fuses equipped in the appropriate Drive Models.

Drive Size / Model		DC-BUS (FBUS)	Braking module (FBR)	Internal Power Supply (FDEC)
Small	DSSA 0510-34	10A LF326 Littelfuse 6.3 x 32	3.15A Wick. 19354 6.3 x 32 (Rbrak.=39)	1A WICKM. 19181 5 x 20
	DSSA 1020-34	15A LF326 Littelfuse 6.3 x 32	3.15A Wick. 19354 6.3 x 32 (Rbrak.=39)	1A WICKM. 19181 5 x 20
	DSSA 1836-34	20A LF326 Littelfuse 6.3 x 32	3.15A Wick. 19354 6.3 x 32 (Rbrak.=39)	1A WICKM. 19181 5 x 20
	DSSA 0306-56	8A gG Ferraz 10.3 x 38	500VFA 4A Ferraz 6.3 x 32 (Rbrak.=56)	1A WICKM. 19181 5 x 20
	DSSA 0510-56	8A gG Ferraz 10.3 x 38	500VFA 4A Ferraz 6.3 x 32 (Rbrak.=56)	1A WICKM. 19181 5 x 20
	DSSA 0918-56	25A gRB Ferraz 10.3 x 38	500VFA 4A Ferraz 6.3 x 32 (Rbrak.=56)	1A WICKM. 19181 5 x 20
Medium	DSSA 2040-56	40A URGB Ferraz 14 x 51	12.5A gRB Ferraz 10.3 x 38 (Rbrak.=20)	1A WICKM. 19181 5 x 20
Large	DSSA 2040-56	40A URGB Ferraz 14 x 51	25A URGB Ferraz 14 x 51 (Rbrak.=11)	1.6A WICKM. 19354 6.3 x 32
	DSSA 3060-56	50A URGA Ferraz 22 x 58	32A URGB Ferraz 14 x 51 (Rbrak.=8)	1.6A WICKM. 19354 6.3 x 32

Notes:

No replacement of any fuse should be carried out until the reason for it's blowing has been rectified.

5. Option list



1. FILTER ON 3 PHASES INPUT SUPPLY
2. MECHANICAL MOTOR BRAKE RELAY
3. RS485 BUS
4. AUXILIARY 24V SUPPLY.

6. Add-on boards

D SDCPROFILE

Add-on board to perform simple movements and interfacing with 24V systems (PLS).

Main characteristics :

- 24 V powered.
- DC-DC conversion for drive power back-up (the position value is kept when main supply of the drive is switched off).
- 14 Outputs potential free (24V 100 mA).
- 16 Inputs 24V potential free.
- Windows Profile User software for easy setting.

To obtain more information about Profile board, contact your SDC distributor.



D SDC IR115 / IR116 / IR117

Synchro-Control, positioning and CANopen interface module for
SERVO DYNAMICS Series 2000 and 4000 drives.

D SDC SERVO net

Positioning control and SERVO net (CAN-BUS type) interfacing module for
Servo Dynamics series 2000 and 4000 drives.

D Future product :

- **Chip card module for parameters saving.**

7. External modules



D SDC, RS232 <-> RS485 converter

Main characteristics :

- Connection of 1..15 drives to a RS232 interface (i.e. computer).
- 24 V powered.
- RS232 header pinout same as drive XSERIAL232 header.
- RS485 header pinout same as drive XSERIAL485 header.
- Mounting on current DIN EN Profiles (Phoenix type UMK-FE).

To obtain more informations about RS485-RS232 converter, contact your SDC distributor.

Distributed by :
Official SDC distributors.

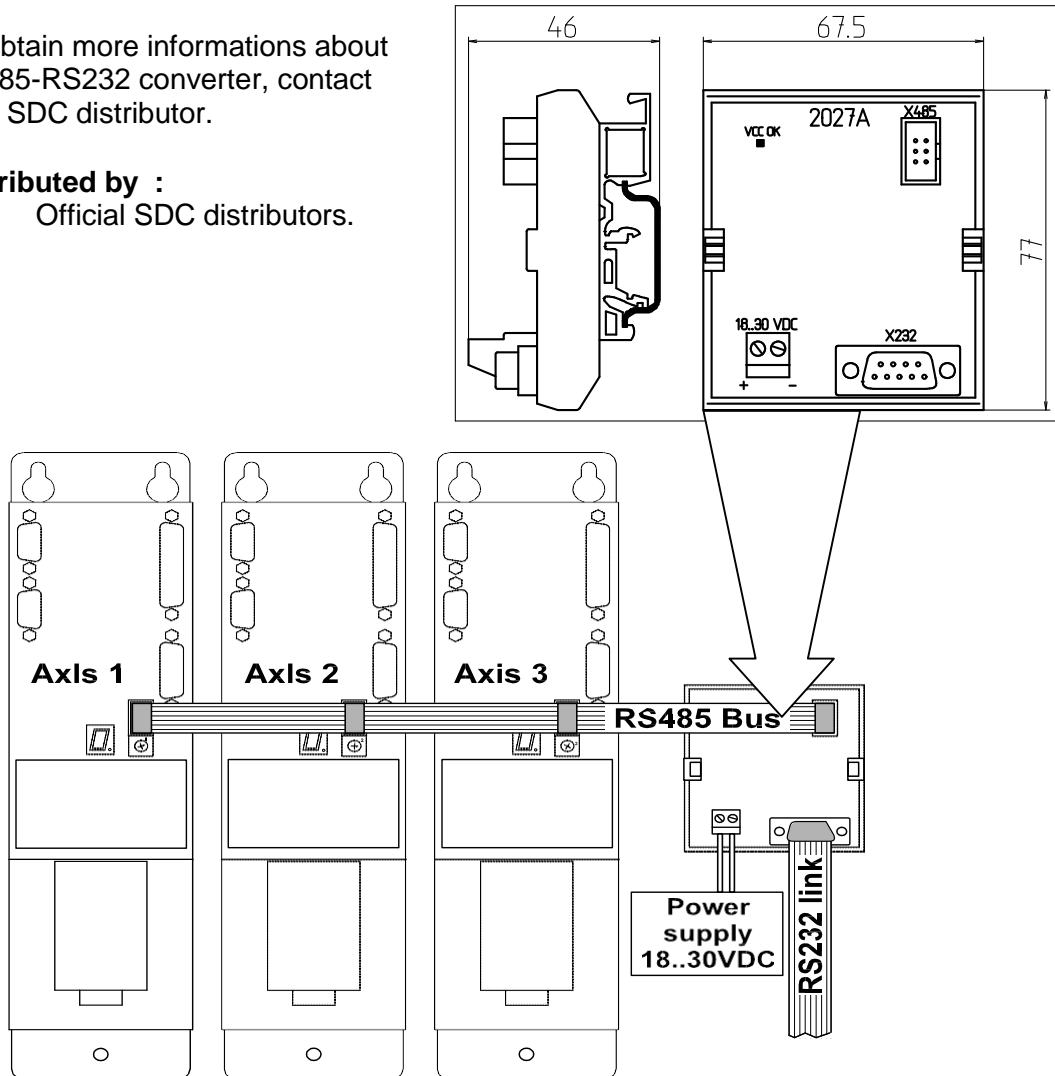



CHAPTER B USER UTILITIES

This section of the manual describes the use of customer utilities. The software is for PC compatible computer.

1. DOS Users

Two softwares are necessary for DOS users : FPRGU.EXE and 2000U.EXE

1.1 FPRGU.EXE : Flash PRoGramming User

This software is used for updating FLASH memory, which contains the drive firmware.

For example, when a new firmware is developed, FPRGU.EXE is able to transfer it to the drive. With this software, it is also possible to check the FLASH contents integrity.

Use of FPRGU.EXE

Connect RS232 Drive connector to the COM1 of the computer with a AT-Link cable. Verify that the axis selector is on 0 and start the following sequence :

FPRGU <ENTER>	Start software
M	Call Monitor function of the drive
T	Transfer
IRTxxx.HEX <ENTER>	Name of the file to transmit
	Wait end of operation
I	Initialise (Reset command)

The drive is ready to work with new firmware



1.2 2000U.EXE : 2000 USER

This software is used to set drive parameters, and to consult the fixed parameters. 2000U offers the possibility to save or load different configurations in DOS text files.

Use of 2000U.EXE

Connect RS232 Drive connector to the COM1 of the computer with a AT-Link cable. Verify that the axis selector is on 0.

When starting, the software shows the first page of parameters (last page : Nr. 15). The ONLINE message is indicated on the top of the screen. The parameter's values on the screen are the drive contents.

Special Functions Keys

The up/down arrow keys <↕> and <-t> are used to select the desired parameter on each page. PgUp, PgDn, TAB and shift-TAB allows to jump one page. The plus key <+>, and minus <-> key change the value of the selected parameter.

Keyboard Shortcuts

<ESC>	Quit software 2000U
F1	Help screen
F2	Store parameters in FLASH
F3	Read a configuration file
F4	Research of active axis (for RS485 link only)
F6	Save parameters in a configuration file
F7	Swap STATUS/ALARMS <-> Parameters list on screen
F9	Switch ONLINE/OFFLINE
SHIFT-F1...SHIFT-F10	Axis 1..10 selecting (for RS485 link only)
CTRL-F1...CTRL-F5	Axis 11..15 selecting (for RS485 link only)
ALT-F7	Hardware reset
ALT-F10	Send manually a command

Change Serial PORT

Run 2000U with argument /COM2, /COM3 or /COM4 in order to change the serial port number.

Warning : A mouse driver on the same port, may cause conflict with the software.



2. Windows Users

The Windows user software runs under Windows 3.1 or later. This software regroups all functions of DOS programs and advanced functions such as integrated scope (if firmware includes this function).

2.1 2000WU.EXE : 2000 Windows User

Like many Windows applications, this software must be installed by starting the SETUP.EXE file, delivered on the installation disk (the SETUP can be executed from the file menu or from the file manager). This operation installs all libraries needed and the application icons.

Installation problems :

1) Installation message :

COMMDLG is in use. Please close all applications and re-attempt Setup.

Solution :

Choose Ignore

Use of 2000WU.EXE

A double click on the  icon starts the application.

Much information are included in the help file, it can be called by the menu « Help » or by a strike of F1 KEY anywhere in the software, to obtain help on the current opened window.

Main functions of 2000 Windows user :



Monitor utility to update the firmware



Parameters viewing and setting



Alarms and status view



Scope function for displaying and printing two different channels (speed, current , resolver signal , ..)



Command generator able to create different condition of command (step, impulse, periodical function, ..)

The pictures are the toolbar's icons, which start these different functions.

Update firmware with 2000WU.EXE

Connect RS232 Drive connector to the COM1 of the computer with a AT-Link cable. Verify that the axis selector is on 0.

Start the application with a double click on it's icon.

- If « *Drive Offline* » indication appears in the toolbar, the drive is not connected at the serial port COM1, then check the connection and if necessary, change the serial port by starting « *Serial link..* » in the menu « *Configuration* ». To check the connection again, start « *Drive information..* » in the « *Utilities* » menu.
- If « *COM1 already used* » message appears, the serial port COM1 is already used by a driver (maybe the mouse driver). In this case « *Serial link* » window appears automatically and it is possible to change the serial port (COM1, COM2, COM3 or COM4, the configuration is saved for a next start of the application when the « *Close* » button is clicked) .

If the drive is correctly connected, the drive type appears below *DRIVE* in the grey box at the

right of the toolbar. To uploading, click on the  icon included in the toolbar. Message *WAITING FOR DRIVE RESPONSE* appears, and if the drive is correctly connected, it disappears after a few seconds. Then, a click on the *SEARCH FILE* button enable the search of the update file (i.e. IRT2007.HEX) in the system (on the harddisk or on a disk). After selection of the file a click on the *TRANSFER PROGRAM INTO DRIVE* button start the update of the firmware or a click on the *COMPARE WITH DRIVE CONTENTS* button enable the check of the FLASH memory contents.



Change parameters values with 2000WU.EXE

Similarly to the firmware update, the Drive must be ONLINE, if not, read the first part of the firmware update procedure.



Click on the  icon to start the *DRIVE PARAMETERS UTILITY* window. Similarly to the DOS application (2000U.EXE), it is possible to read or write parameters values.

The values are given in three different numbers; decimal value, hexadecimal value and meaning value. The decimal and the hexadecimal value are the real internal value of the drive (16 bit), and the meaning is a corrected value with a unit. Only a few parameters have a meaning value. For the others, meaning value is the same as the decimal value, without unit.

To change parameter value, use the scroll bar to move the grid on the parameter, click on the value that you want to modify, edit it and strike ENTER key.

There are three possibilities to write the value :

- Decimal (i.e. : 15567 or -23203)
- Hexadecimal (i.e. : (800)h)
- Meaning value(i.e. : 8 A or 8)

When the ENTER key is pressed, the value is sent to the drive and is read again for checking the modification.

A click on the *SAVE PARAMETERS IN DRIVE* button stores all parameters in the FLASH memory of the drive.

3. Serial Link

3.1 Dialogue protocol

This protocol is used to exchange data between computer or CNC and one axis (RS232, min 3 wires) or several axes (max. 15, RS485, 5 wires in parallel).

In RS485, all axes are listening, while answer is given only by concerned axis, other transmitters being in tristate

Orders format :

<STX><ADDRESS><COMMAND><PARAM1><PARAM2><PARAMn><ETX><BCC>

Explications :



<STX> Start of text.

<ADDRESS> Axis address.
The address is given in ASCII (address + 48)

<COMMAND>Command to execute.

<PARAM1> Address parameter or command complement.
For the address, address value + 48..

<PARAM2..n>Optional parameters.
If datas, 4 digits hexadecimal value.

<ETX> End of text.

<BCC> : Block check 8 bit
<STX > XOR <ADDRESS> XORXOR <ETX>

Commands list:

Read parameter	"R"	address
Write parameter	"W"	address + parameter
Reset hardware	"CH"	
Store in FLASH	"ST"	

Answers format :

<STX><ADDRESS><COMMAND><PARAM1><PARAM2><PARAMn><ETX><BCC>
or
<ACK>
or
<NAK>

The answers are different depending on received command :

Write parameter :

Command : No Axis Write Address Data
Answer : ACK if order understood and executed
NAK if BCC wrong and No Axis OK

Read parameter :

Command : No Axis Read Address
Answer : No Axis Read Address Data
NAK if BCC wrong and No Axis OK



3.2 Dialogue examples

Command	Drive answer
Read parameter no 11 axis no 2 {02}{50}{82}{59}{03}{90}	Parameter no 11 = 27 = (1B)h {02}{50}{82}{59}{48}{48}{49}{66}{03}{41}
Write 127 the parameter no 28 of axis no 13 {02}{61}{87}{76}{48}{48}{55}{70}{03}{86}	ACK {06}
Store parameters in FLASH of axis no 2 {02}{50}{83}{84}{03}{52}	Nothing



CHAPTER C DRIVE PARAMETERS

1. Parameters description

The 208 parameters of the drive are divided as follows :

Parameter address	Description	Access
0..5	Motor parameters.	Read/write Parameters
6..40	Installation parameters.	
41..45	Scope parameters.	
48..53	Command parameters.	
60..63	Internal register (for tests,..).	
64..95	Status parameters.	Read only parameters
100..179	Scope values.	
180..207	Diverse parameters	

For a few read/write parameters, a change of the value by a write order isn't directly considered. An indication is given in the « ST. » column for the read/write parameters :

- **C** : compute order must be sent to the drive to consider the change of the parameter (only for SSI)
- **S** : « Store parameters in FLASH » must be sent to the drive, for it to consider the change.
- **Nothing**: the change is directly considered.

Other abbreviations :

- **R/W** : read/write parameter.
- **R** : read only parameter.
- **O** : optional parameter (depend of firmware)
- **n.i** : parameter not included at this time.

Important :

When VXXX→ (i.e. V2005→) is indicated in the table, the function is only available with specified firmware version (i.e. version 2005) or higher version.



1.1 Global list of parameters

Addr.	St.	R/W	Unit	Limits	Description	Example	Detail
0		R/W	-	1..6	Pair of motor Poles		pg 48
1		R/W	$1/2^{16}$ turns	8000h..7FFFh	Resolver shift angle	16384 \leftrightarrow $1/4$ turn	pg 48
2	S	R/W	-	0,1	Motor Thermostat n/o or n/c		pg 48
3		R/W	$\frac{1}{7FFF_h} \cdot I_{MAX_DRIVE}$	0..7FFFh	Maximum motor current	With $I_{MAX_DRIVE} = 20 A_{RMS}$ 19988 \leftrightarrow 12.2 A_{RMS}	pg 48
4	S	R/W	$\frac{1}{7FFF_h} \cdot I_{MAX_DRIVE}$	0..3FFFh	Nominal motor current	With $I_{MAX_DRIVE} = 20 A_{RMS}$ 10322 \leftrightarrow 6.3 A_{RMS}	pg 48
5	S	R/W	ms	0..7FFFh	I^2t motor limited to maximal drive I^2t	12534 \leftrightarrow 12534 ms	pg 49
6		R/W		1..7FFFh	Current loop Proportional gain (Kp)		pg 59
7		R/W		0..7FFFh	Current loop Integral gain (Ki)		pg 59
8		R/W		0..7FFFh	Current loop Differential gain (Kd)		pg 60
9		R/W	$\frac{0.1 \text{ Electric degree}}{1'000 \text{ RPM}}$	0..100	Phase advance	12 \leftrightarrow 1.2° electric at 1000 RPM	
10		R/W	$\frac{1}{7FFF_h} \cdot I_{MAX_DRIVE}$	-1,0..7FFFh	External I-limit/Loop select V2005 \rightarrow negative value enable the selection speed or current loop.	With $I_{MAX_DRIVE} = 20 A_{RMS}$ 5161 \leftrightarrow 3.2 A_{RMS}	pg 55
11		R/W					
12		R/W	$1/8000_h$	6000h...A000h	Adj.factor sine/cosine	35234 \leftrightarrow Factor 1.075	pg 50
13	O	R/W	-	0,1	Power down back-up		pg 56
14	S	R/W	-	0..3	Encoder Input configuration bit0:encoder inputs direct to output bit1:count reset on Z input		pg 53
15	O	R/W	-	0..1023	Encoder marker pulse period 0 : each period 1 zero pulse 1..1023 : 1 zero pulse each 2..1024 period	235 \leftrightarrow 1 zero pulse each 236 period	pg 53



Addr.	St.	R/W	Unit	Limits	Description	Example	Detail
16		R/W					
17	S	R/W	1/revolution	1..2048	Encoder resolution 1025..2048 : Extrapolated resolution	234 ⇔ 234 pulse by revolution	pg 52
18	S	R/W	-	0..6	Encoder marker pulse width 0: ¼ period channel A, gated B\ 1: ½ period channel A, gated B\ 2: 1 period channel A, gated B\ 4: ¼ period channel A, gated A\ (V2005→). 5: ½ period channel A, gated A\ (V2005→). 6: 1 period channel A, gated A\ (V2005→).		pg 52
19		R/W	1/2 ¹⁶ turns	8000..7FFFh	Encoder marker pulse position	8192 ⇔ 1/8 turns	pg 52
20		R/W		1..7FFFh	Speed loop Proportional gain		pg 61
21		R/W		0..7FFFh	Speed loop Integral gain		pg 61
22		R/W		0..7FFFh	Speed loop Differential gain		pg 61
23	S	R/W	0.925 RPM	-8191..8191	Maximum speed (for 10V input)	3200 ⇔ 2960 RPM	pg 50
24	S	R/W	-	0..3	End limit switches n/o or n/c V2005→ : Bit 15 enable special function (see detail page)		pg 54
25	S	R/W	-	0..3	Direction stop		pg 54
26		R/W	-	0,1	Speed or Current loop control 0: Speedloop 1: Currentloop		pg 57
27		R/W	-	0,1	Digital or Analogue command 0: Digital 1: Analogue		pg 57
28		R/W	$\frac{1}{7FFF_h} \cdot V_{MAX}$	-255..255	Analogue command offset with speedloop control	With V _{MAX} = 3000 RPM 22 ⇔ 2 RPM	pg 57
			$\frac{1}{7FFF_h} \cdot I_{MAX_DRIVE}$		Analogue command offset with currentloop control	With I _{MAX DRIVE} = 10 A 33 ⇔ 0.01 A	



Addr.	St.	R/W	Unit	Limits	Description	Example	Detail		
29		R/W	55.6 RPM/s	0,1..7FFFh	Command Slope 0 : No ramp	100 ⇔ 556 RPM/s 0 ⇔ No ramp	pg 58		
30	S	R/W	-	0,2	Monitoring Relay Rdy/Ala/Ena 0 : Relay-Ready (Alarm inverted) 1 : Relay-Alarm 2 : Relay-Enable (V2005→)		pg 55		
31	n.i.	R/W	-	0,1,2	Enable hardware/serial/edge				
32		R/W	ms	0..32000	Watchdog software communication (V2005→)		pg 56		
33	S	R/W	-	0..FFFFh	Alarm latch		pg 55		
								Bit	Description
								0	Latch alarm 7 (over or under voltage alarm)
								2	Latch alarm d (earth fault)
								4	Latch alarm 2 (I ² t) (V2005→)
6	Latch alarm b (over speed)								
34		R/W	REV/4096	0..256	Encoder dead window (V2005→)	5 ⇔ dead window = 5 REV/4096	pg 52		
35		R/W	ms	0,1..136	Motor brake delay (V2005→)	0 ⇔ Motor brake inactive 20 ⇔ 20 ms delay	pg 56		
36		R/W							
37		R/W							
38	n.i.	R/W	-	0,1	Control IU/CU				
39	n.i.	R/W			Sleep mode				
40	O	R/W	Compute period (~132 us)	0..32000	SSI cyclic transmit period	1504 ⇔ 200 ms period	pg 54		
41		R/W			Scope parameter		pg 34		
42		R/W			Scope parameter				
43		R/W			Scope parameter				
44		R/W			Scope parameter				
45		R/W			Scope parameter				



Addr.	St.	R/W	Unit	Limits	Description	Example	Detail
46		R/W			Scope options		
47		R/W					
48	O	R/W	-	0..FFFFh	SSI command		pg 55
49	O	R/W	-	0..255	Cyclic parameter address		pg 55
50		R/W	0.925/4 RPM	8000..7FFFh	Digital command with Speedloop control	13838 ⇔ 3200 RPM	pg 57
			$\frac{\sqrt{2}}{7FFF_h} \cdot I_{MAX_DRIVE}$	8000..7FFFh	Digital command with Currentloop control	with $I_{MAX_DRIVE} = 20 A_{RMS}$ 6226 ⇔ 3.8 A_{RMS}	
51		R/W	-	0..255	Status display 7 segment value 0 : Internal status, other values : bit 7 = DP, bit 6..0 = SEG A..G	146 ⇔ DP + SEGMENT_F + SEGMENT_C	pg 57
52		R/W	revolution	0..FFFFh	Motor revolutions counter		pg 57
53	O	R/W	-	0..FFFFh	Encoder input counter		pg 54
54		R/W					
55		R/W					
56		R/W					
57		R/W					
58		R/W					
59		R/W					
60		R/W			Internal register		
61		R/W			Internal register		
62		R/W			Internal register		
63		R/W			Internal register		
64		R			Status register		
		Bit	Description		Drive display		
		0	Fault Int : Over or under voltage of DC Bus				
		1	FO N				
		2	FO UP	Powermodule fault (over I, over Temp)			
		3	FO VP				
		4	FO WP				
	5	DT U	Earth fault				



Addr.	St.	R/W	Unit	Limits	Description	Example	Detail
	6		DT V				
	7		DT W				
	8		Thermostat motor				
	9		V6 OK				
	10		End-switch 1				
	11		End-switch 2				
	12		Power down				
	13		External I-limit/Loop select input				
	14		AC fail				
	15		Enable/disable		0/1		
65		R			Alarm register		
	Bit		Description		Drive display		
	0		Fault Int : Over or under voltage alarm		7		
	1		Powermodule fault		6		
	2		Earth fault		d		
	3		Internal over temperature (>80°C)		4		
	4		I ² t (only if latched)		2		
	5		Resolver fault		5		
	6		Over Speed		b		
	7		Motor link fault		C		
	8		Thermostat motor		3		
	9						
	10						
	11						
	12						
	13		Software watchdog		9		
	14		Firmware not OK		F		
	15		Parameters not OK		E		
66		R	°C		Heatsink temperature	32 ⇔ 32 °C	
67		R	$\frac{2\sqrt{2}}{7FFF_h} \cdot I_{MAX_DRIVE}$	8000h..7FFFh	Instantaneous motor current	With I _{MAX_DRIVE} = 20 A _{RMS} 7241 ⇔ 12.5 Apeak	
68		R	0.925 RPM	8000h..7FFFh	Instantaneous motor speed	2667 ⇔ 2467 RPM	
69		R	1/2 ¹⁶ turns	0..FFFFh	Resolver position within a revolution	4096 ⇔ 1/16 turn	
70		R					
71		R	-	1..15	Axis address		



Addr.	St.	R/W	Unit	Limits	Description	Example	Detail
72		R	-		Monitor Version		
73		R	-		Firmware Version		
74		R	-		FPGA Version		
75		R					
76		R					
77		R					
78		R					
79		R					
80		R					
81		R					
82		R			Fan switch on temperature	40 ⇔ Fan switch on at 40°C, switch off at 35°C	
83		R			PWM frequency		
84		R			Commutation dead time		
85		R					
86		R	A _{RMS}		Maximum drive current (I _{MAX_DRIVE})	20 ⇔ 20 A _{RMS}	
87		R	A _{RMS}		Nominal continuous drive current	10 ⇔ 10 A _{RMS}	
88		R	ms		Maximum drive I ² t		
89		R	-		Power modules		
90		R	V _{RMS}		Line voltage input	400 ⇔ 400 V _{RMS}	
91		R	-		Options		
92		R	-		Hardware version		
93		R	-		Delivery date	1497 ⇔ week 14 in 1997	
94		R	-		Customer		
95		R	-		Serial Number		
96		R	-		Firmware abilities		
97		R	$\frac{-10}{7FFF_h} V$	8000..7FFFh	External analogue command 10V		
98		R	$\frac{2.5}{7FFF_h} V$	8000..7FFFh	External analogue command 2.5V		



Addr.	St.	R/W	Unit	Limits	Description	Example	Detail
99		R	see parameter 50		Internal digital command		
100	O	R			Scope values		
...	O	R			Scope values		
179	O	R			Scope values		
180		R	-		Resolver Sine		
181		R	-		Resolver Cosine		
182		R	$\frac{2\sqrt{2}}{7FFF_h} \cdot I_{MAX_DRIVE}$	8000..7FFFh	Current Command		
183		R					
184		R					
185		R	$\frac{2\sqrt{2}}{7FFF_h} \cdot I_{MAX_DRIVE}$	8000..7FFFh	Phase U current		
186		R	$\frac{2\sqrt{2}}{7FFF_h} \cdot I_{MAX_DRIVE}$	8000..7FFFh	Phase V current		
187		R	$\frac{2\sqrt{2}}{7FFF_h} \cdot I_{MAX_DRIVE}$	8000..7FFFh	Phase W current		
188		R					
189		R					
190		R					
191		R					
192		R			I ² t threshold		pg 49
193		R			Instant I ² t		pg 49



1.2 Scope parameters

Scope parameters :

5 parameters for scope settings (Address 41..45).

80 read only parameters for the measuring values (Address 100..179).

Use of scope function

When a time scale different of 0 is written, the drive starts the measurement, the parameters 100..179 are filled cyclically with samples.

When trigger condition is satisfied, the drive saves the position (trigger position parameter) and continues the measurement during the number of post-trig samples defined. At the end of the measurements, time scale parameter is set to 0 to indicate the end.

Add		Description	Comment
41		Time scale	Factor of 133 us for the sampling time.
42	HB	Parameter 1 address (channel 1)	Address of parameter 1 to measure
	LB	Parameter 1 scale	Number of shift (left shift for positive value and right shift for negative value)
43	HB	Parameter 2 address (channel 2)	Address of parameter 2 to measure
	LB	Parameter 2 scale	Number of shift (left shift for positive value and right shift for negative value)
44	HB	Slope positive/negative or null	null for no trigger
	LB	Trigger value	Threshold value
45	HB	Trigger position	Address where the trig point is (100..179)
	LB	Number of Post-trig samples	0 : 100 % pretrig 80 : 0 % pretrig
46		Scope options (since firmware V2005)	bit 15 = 0 --> saturation (when values overshoot with the defined scale). bit 15 = 1 --> no saturation (for bit wise operations or low bits watching)
100	HB	Value 1 of parameter 1	Measured value
	LB	Value 1 of parameter 2	Measured value
..			
179	HB	Value 80 of parameter 1	Measured value
	LB	Value 80 of parameter 2	Measured value



CHAPTER D SETTING TO WORK

1. Wiring

The wiring of the drive series 2000/4000 must be carried out according to the schematic in these instructions. Local wiring regulation must be observed.

Special attention should be paid with respect to wiring rules regarding ground, earth and neutral.

The earth wire to the drive, motor and housing must be as short as possible and connected to a common earth point.

The global wiring plan is represented in Figure 1 on page 36.

1.1 Cable lengths and cross-sections

Drive type	Supply cable see note (1) mm ²	Motor cable mm ²	Control signals cables mm ²
DSSA 0510-34	1.5	1.5	min. 0.14
DSSA 1020-34	1.5	1.5	
DSSA 1836-34	2.5	2.5	
DSSA 0306-56	1.5	1.5	
DSSA 0510-56	1.5	1.5	
DSSA 0918-56	1.5	1.5	
DSSA 2040-56	2.5	2.5	
DSSA 3060-56	4	4	

Length of cable between drive and motor : max. 15 m.

(1) Note :

The PE terminal of the drive must be permanently connected to the earth. The cross-section of the protective conductor must be at least 10 mm² Cu.



1.2 Global wiring plan

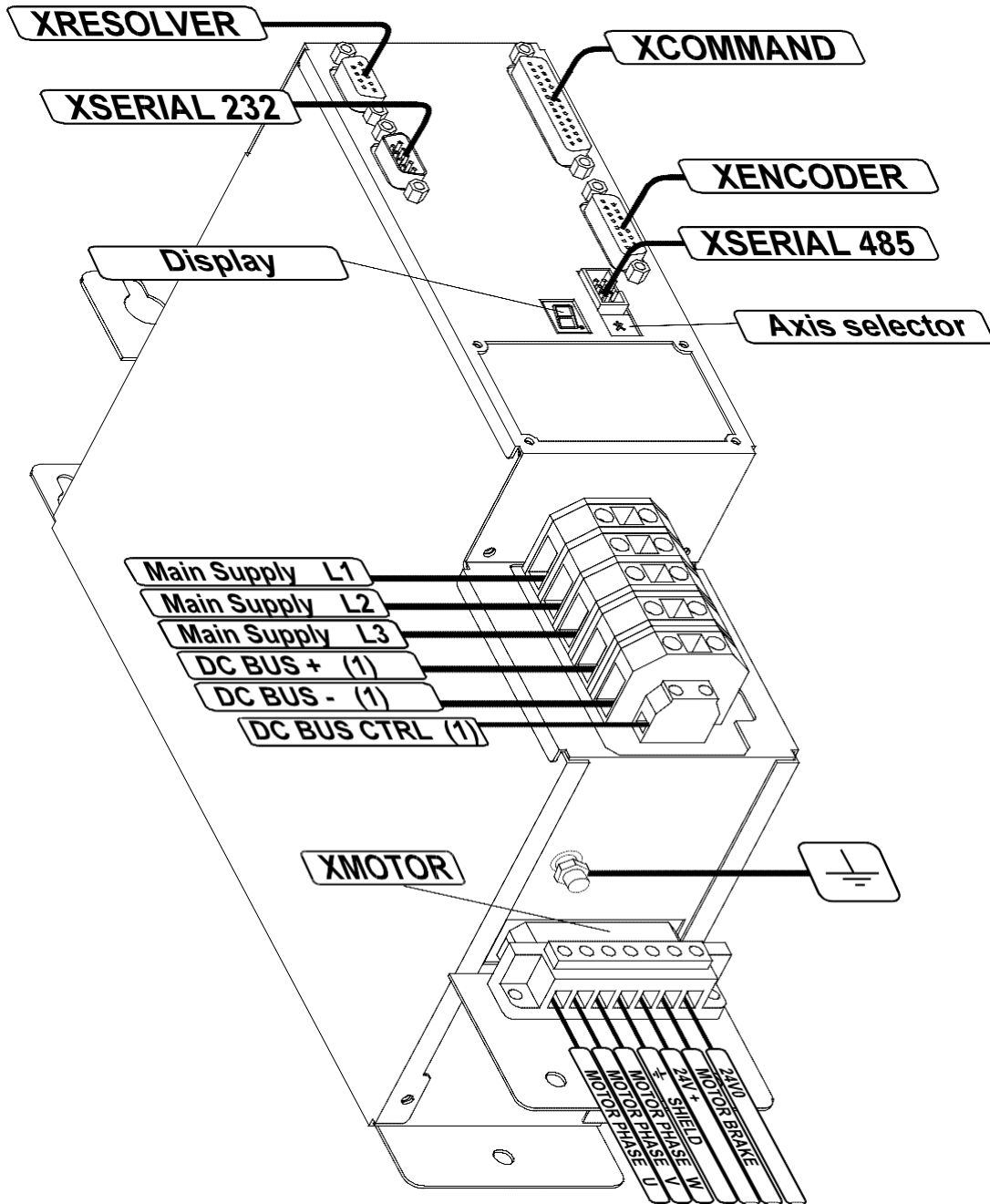

Figure 1 - Global wiring plan

(1) Note:

DC BUS +/- and DC BUS CTRL terminals are not present when drive is equipped with « EMC filter » option.



1.3 Control unit wiring

XRESOLVER

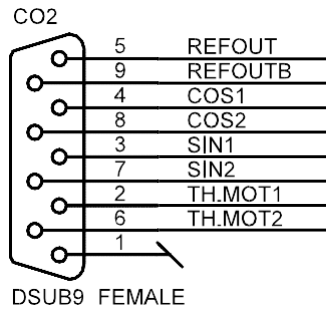

XCOMMAND

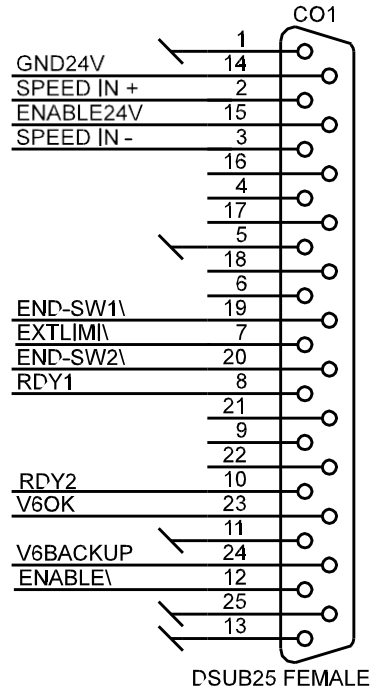

XSERIAL 232

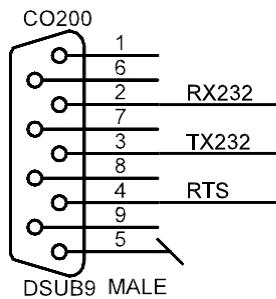

XENCODER

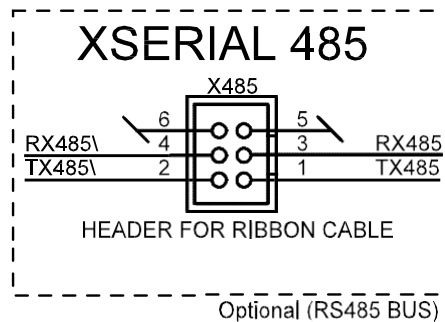
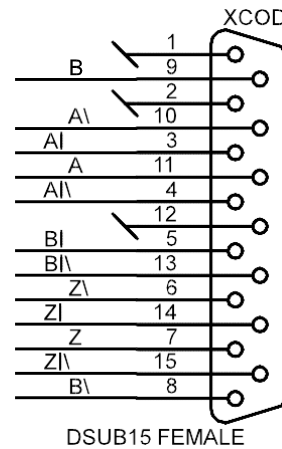



1.3.1 XRESOLVER

Correct wiring of the resolver is the **precondition** for good and reliable operation of the servo-amplifiers series 2000 & 4000. Non-compliance of the instructions operations in this manual will cause a **deterioration of the specified performances**.

A cable with the following characteristics is needed:

- 3 pairs of conductors 0,14 mm² twisted in pairs and shielded separately.
- 2 conductors of 0,5 mm²
- an overall shield contacted with the previous shields.

The cable wiring should be done as Figure 2.

The overall shield must be connected to both the motor and the amplifier. It should be noted that the contact from the overall shield to amplifier and motor must be made by using as much contact area as possible. The use of "Pig Tail" on the overall shield should be avoided. It is recommended to follow the convention (signal / conductor colour) used in this manual.

Contacts 2 and 6 are intended for the motor thermal switch wiring. The contact should be either of type normally closed, or of type normally open. It should have the following characteristics :

contact closed : 1 k ohm
 contact opened : 10 k ohm

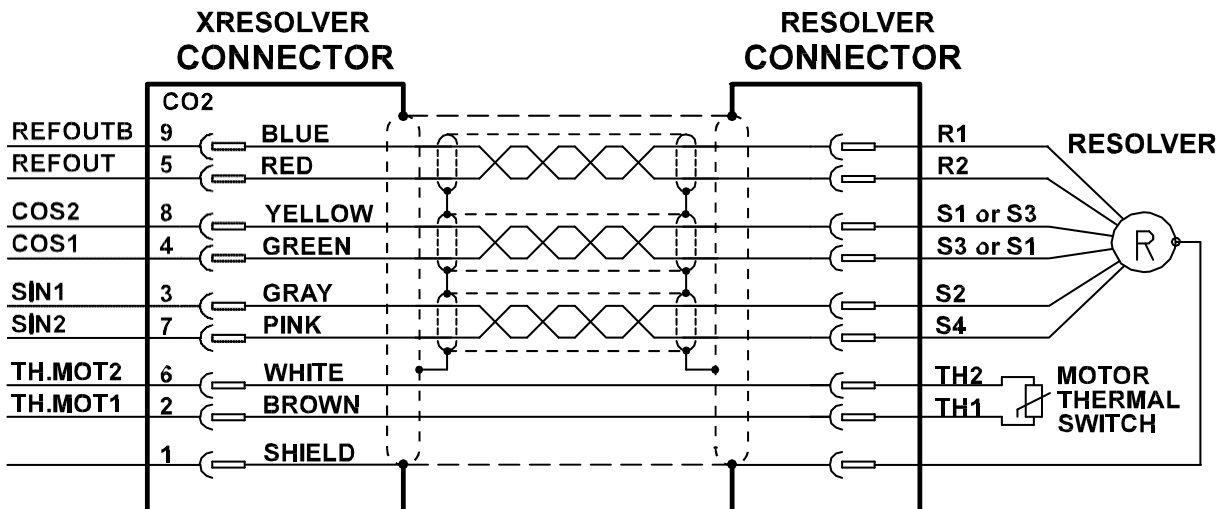

Figure 2 - Resolver and motor thermal switch wiring



1.3.2 XCOMMAND

Pin Nr.	Pin name	Function	Pin type
1,5,11,13	GND	General purpose ground for digital input, output and reference for SPEED IN.	Power ground
2	SPEED IN+	Non-inverted differential input command Max input voltage +/- 20VDC Max differential input voltage +/-10V Differential input impedance : 8kΩ	Analogue input See note (1)
3	SPEED IN-	Inverted differential input command Max input voltage +/- 10VDC Max differential input voltage +/-10V Differential input impedance : 8kΩ	Analogue input See note (1)
7	EXTLIMI\	Digital input for current limitation to the programmed value. Active low. Internal pull-up 4k7 to 5V.	Digital input
8,10	RDY1,RDY2	Potential free contact of the make contact relay. 24 VDC, 0.5 A, 10 VA	Contact output
12	ENABLE\	Passive ENABLE. Close this input to GND to active the power stage. Internal pull-up 4k7 to 5V.	Digital input
14	GND 24V	Ground of the active optocoupled ENABLE (potential free, max 50VDC to GND).	External ground
15	ENABLE 24V	Active optocoupled ENABLE. Max input voltage : 30 VDC (with respect to GND 24V) Active level : 20..30 VDC / 5kΩ (potential free, max 50VDC to GND)	Power input
19	END-SW1\	Limit switch input affecting the positive speed command. Internal pull-up 4k7 to 5V. See note (2)	Digital input
20	END-SW2\	Limit switch input affecting the negative speed command. Internal pull-up 4k7 to 5V. See note (2)	Digital input
23	V6OK	High if 6V is internal powered. Output voltage 0..6 VDC, High Z Do not load with less than 10 KΩ	Digital output
24	V6BACKUP	External 6V power supply input for the CU and optional IU boards. Supply voltage: 6..7 VDC Supply current : 500mA max + IU current.	Power input
25	GND	Ground for the external 6V power supply.	Power ground

Pins 4,6,9,16,17,18,21,22 are not used.

(1) Common mode voltage range (CMVR) +/-10V if common on SPEED IN-

(2) Close this input to GND to inhibit or to free the movement (depend of parameter 24 configuration).



The on-board relay is **normally open contact**. The rating of his contact is as follows:
24 V - 0,5 A - 10 VA

1.3.3 XENCODER

The connector XENCODER provides simulated encoder signals and allows to read signals coming from an external encoder.

Pin Nr.	Pin name	Function	Pin type
1,2 & 12	GND	Internal ground of the CU board	Power ground
3	AI	Non-inverted impulse A input	Differential input
4	AI\	Inverted impulse A input	Differential input
5	BI	Non-inverted impulse B input	Differential input
6	Z\	Inverted zero impulse output	Differential output
7	Z	Non-inverted zero impulse output	Differential output
8	B\	Inverted impulse B output	Differential output
9	B	Non-inverted impulse B output	Differential output
10	A\	Inverted impulse A output	Differential output
11	A	Non-inverted impulse A output	Differential output
13	BI\	Inverted impulse B input	Differential input
14	ZI	Non-inverted zero impulse input	Differential input
15	ZI\	Inverted zero impulse input	Differential input



Simulated incremental encoder signals provided on connector XENCODER:

The provided signals A, A / B, B / Z, Z / and GND are similar to the signals of an incremental encoder signal with differential outputs. The line driver used on-board is type 75172. The line receiver of the position controller should be type 75175.

These signals are always present and do not require any external supply.

Incremental encoder signals read on connector XENCODER:

The read signals AI, AI/ BI, BI/ ZI, ZI/ and GND are interpreted as incremental encoder signals with differential outputs. The line receiver used on-board is type 75175.

Encoder cable wiring:

The GND signal should be common to the position controller and to the servo-amplifier.

The cable connecting the position controller to the servo-amplifier should be shielded with twisted pairs for differential input and output. The shield must be connected to both the position controller and the amplifier. It should be noted that the contact from the shield to the metallic case of the amplifier plug-in connector (XENCODER) and the contact from the shield to the position controller metallic cabinet must be made by using as much contact area as possible. The use of "Pig Tail" on the shield should be avoided.

1.3.4 XSERIAL 232 and XSERIAL 485

The serial link is used to set or monitor drive parameters stored in non-volatile memory using the configuration program.

The serial links could be also used to down-load an up-dated firmware or an other firmware version.



Pin-out of the RS232 connector (XSERIAL 232)

Pin Assignment for Serial Port on the Drive			Pin Nr. for Serial Port on P.C.	
Pin Nr.	Pin name	Function	9-Pin connector	25-Pin Connector
1,6,7,8 & 9	N.C.	Not connected (potential free).		
2	RX232	Transmit Data output	3	2
3	TX232	Receive Data input	2	3
4	RTS	Request To Send output	6 & 8	6 & 5
5	GND	Common ground	5	7

The minimal wiring of the RS232 serial cable is as follows:

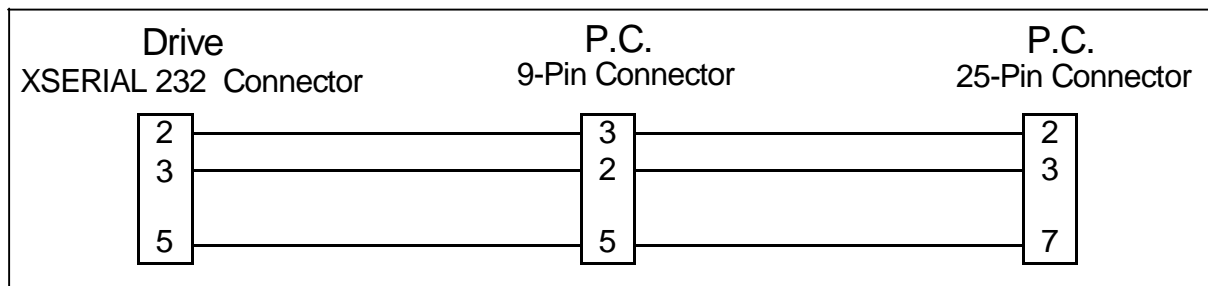

Pin-out of the RS485 connector (XSERIAL 485)

Pin Nr.	Pin name	Function
1	TX485	Non-inverted Transmit Data output
2	TX485\	Inverted Transmit Data output
3	RX485	Non-inverted Receive Data input
4	RX485\	Inverted Receive Data input
5 & 6	GND	Common ground



1.3.5 Axis selector

RS232 link



The axis selector must be on « 0 », the drive replies to RS232 messages sent to address Nr.1.

RS485 link



The axis selector defines the axis number of the drive, from address 1 to 15. The drive will reply to RS485 messages sent to the corresponding address (Axis selector on 5 → drive reply to messages sent to address Nr. 5).

Notes :

- When the drive does not include the RS485 option (axis selector nonexistent), only the RS232 link is usable (message constituted with address Nr.1).
- See 3.1 Dialogue protocol description, page 23, to know the way for the construction of messages.
- The drive must be resetted (send of Reset order or switch Power OFF/ON) to enable a change of the selector position.
- A firmware upgrade is only possible with a RS232 link.
Exception : when drive is programmed with a monitor version 300_h (or higher), the firmware update is also possible by RS485 (the parameter 72 indicates the monitor version).

1.4 XMOTOR Connector



XMOTOR CONNECTOR

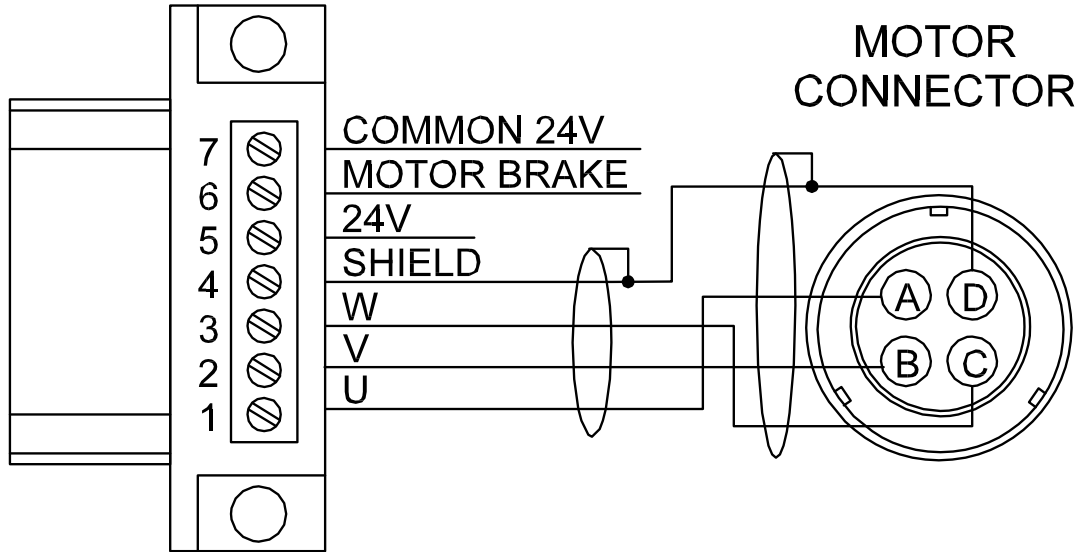

Pin Nr.	Pin Name	Function	Pin Type
1	MOTOR PHASE U	Motor terminal	Power Output
2	MOTOR PHASE V	Motor terminal	Power Output
3	MOTOR PHASE W	Motor terminal	Power Output
4	SHIELD	Motor cable shield and PE	
5	24V (option)	External Power 24VDC Max input voltage : 30VDC	Power Input
6	MOTOR BRAKE (option)	Motor Brake terminal Max output current : 2.5A	Output
7	COMMON 24V (option)	Ground for the external 24VDC and for motor brake	Power Ground

Note :

See Motor brake delay parameter description, page 56, for more information about Motor brake.

1.4.1 Determining the motor phases (without drive)

Important :



This operation will be done only when the three-phase motor order is unknown (motor prototype or no documentation).

A DC supply of about 3A is necessary for this operation.

The procedure is as follows :

1. Determine arbitrarily phase **U** as one of the 3 motor phases.
2. Connect **U** to «+» and a **2nd phase** motor to «-» of the DC supply.
3. Switch supply on. The shaft will move to a stable position.
4. Mark the new shaft position with a pencil, at top center.
5. Switch supply off, disconnect the «-» from the **2nd motor phase** and reconnect the «-» to the **3rd motor phase**. Switch supply on and observe the axis rotation direction (report the direction in the table below).
6. Mark with a pencil the new shaft axis position.
7. With the help of the table below, determine the 2 unknown motor phases :

Sense of axis rotation	2 nd Motor phase	3 rd motor Phase
Clockwise	V	W
Anti-clockwise	W	V

When this operation is done, it is important to define the resolver shift angle parameter (P1), see section 4.1 of chapter D.

2. Display indications

The display shows the state of the drive and of the motor.



Drive in function torque enable



Drive in function torque enable and zero position



Drive in function torque disable



Drive in function torque disable and zero position



The decimal point is « ON » when the motor turns clockwise



The decimal point is « OFF » when the motor turns anti-clockwise

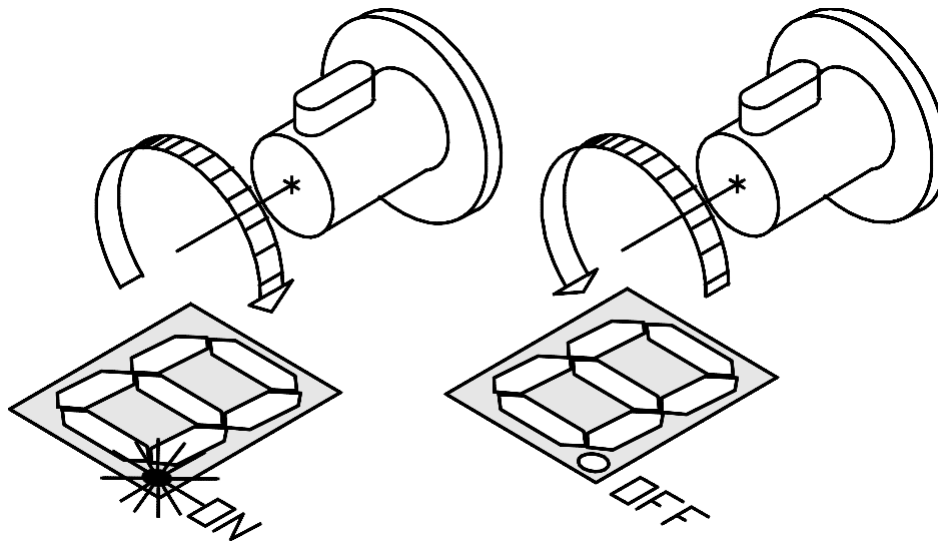

If the decimal point lights up during anti-clockwise rotation, wires S1 (COS1) and S3 (COS2) of resolver connector must be inverted (see section 0 of chapter D).

2.1 Alarms

The alarm H has the most priority (following F, E, d, C, b, A, 9, ... etc.). If some alarms takes place simultaneously, only the one with the higher priority will be displayed.



I^2t
(only if latched)



Thermostat motor



Internal over temperature (>80°C)



Resolver fault



Power module fault



Over or under voltage



Software watchdog



Over speed when 125% of max. motor speed is reached. (only if latched)



Motor link fault



Earth fault



Parameters not OK



Firmware not OK



Hardware incompatibility
define which alarm must be latched.

The Parameter 33 (Alarm latch) allows you to

2.2 Warnings



Over current, appears during 1 sec when 125% of maximum drive current is reached (bad regulation parameters).



I²t reached. (if not latched)



3. Parameters settings

3.1 Motor parameters

These parameters depend on the connected motor characteristics. This information is generally indicated on rating plate of the motor or given in the motor data sheet.

PAIR OF MOTOR POLES, ADDRESS 0

This parameter must contain the number of motorpoles pair. This number can be between 1 and 6 pairs.

RESOLVER SHIFT ANGLE, ADDRESS 1

This value correspond to shift angle between the resolver signal and the motor, from $-\frac{1}{2}$ turn to $+\frac{1}{2}$ turn. The zero value means a ideal combination between the resolver and the motor. See also section 4.1 of chapter D (How to set the resolver shift angle parameter, page 63)

MOTOR THERMOSTAT N/O OR N/C, ADDRESS 2

Type of thermal switch included in the motor, 1 for a normally closed contact and 0 for a normally open contact. Closed and opened contact features :

- contact closed : $\leq 1 \text{ k}\Omega$
- contact opened : $\geq 10 \text{ k}\Omega$

MAXIMUM MOTOR CURRENT, ADDRESS 3

The maximum motor current value is given to the drive with the following equation :

$$\frac{I_{MAX_MOTOR} \cdot 7FFFh}{I_{MAX_DRIVE}}$$

I_{MAX_DRIVE} AND I_{MAX_MOTOR} in A_{RMS} .

This value must be between 0 and 7FFFh, that mean between 0 and I_{MAX_DRIVE}

NOMINAL MOTOR CURRENT, ADDRESS 4

The nominal motor current value is given to the drive with the following equation :

$$\frac{I_{NOMINAL_MOTOR} \cdot 7FFFh}{I_{MAX_DRIVE}}$$

With I_{MAX_DRIVE} AND $I_{NOMINAL_MOTOR}$ in A_{RMS} .

This value must be between 0 and 3FFFh, that mean between 0 and $I_{NOMINAL_DRIVE}$



I²T MOTOR, ADDRESS 5

The I²t motor (P5) is defined as elapsed time in « ms » when I²t value progresses from zero to I²t threshold (P192) when drive current equals the double of nominal current.

I²t evolution for $I_{INST} = I_{NOM}$ and $I_{INST} = 2 \cdot I_{NOM}$:

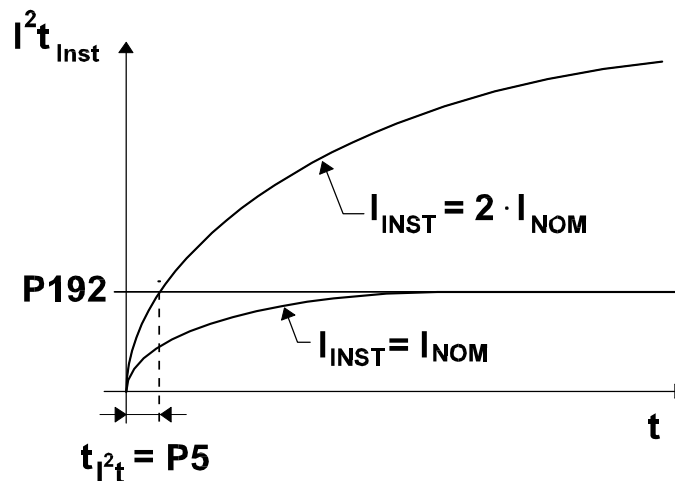

Instant I²t, Address 193 :

Instant I²t (P193) is the instantaneous value of the I²t. In comparison of the I²t threshold, this parameter gives an information about motor load.

I²t threshold, Address 192 :

The I²t threshold (P192) is defined as equal to the I²t value when continuous drive current equals nominal current.

I²t warning (if I²t not latched) :

When I²t value reaches the I²t threshold, the maximal current is limited to nominal current and 2 is displayed while I²t value is higher than I²t threshold.

I²t alarm (if I²t latched) :

The drive power stage is disabled when the I²t value reaches the I²t threshold and 2 is displayed.

The instant I²t in comparison of I²t threshold can be observed on the Scope of the user software. This method is useful to determine and to check the I²t value and the motor load.



MAXIMUM SPEED (FOR 10V INPUT), ADDRESS 23

Maximum motor speed, this value is generally indicated on the rating plate of the motor. Divide the RPM value by 0.925 to obtain the drive value.

For analogue command mode, this value fixes the speed range (max input voltage correspond to this speed).

The over speed alarm is activated (if latched) when the motor speed value is equal to or higher than 125% of the maximal speed value.

ADJ.FACTOR SINE/COSINE, ADDRESS 12

Asymmetric resolver adjustment :

factor = maximum cosine value / maximum sine value

Parameter 12 = 8000h • factor (6000h...A000h ϕ factor = 0.75 .. 1.27)

The windows user software allows you to compute automatically this factor by a double click on the value of parameter 12 in the « Parameters values » window (just move motor position to each maximum values of sine and cosine).

3.1.1 Example of motor parameters

Example with DRIVE type 2010

MOTOR FEATURES (EXAMPLE):

Poles pairs	4	
Nominal Current	6.68	A
Nominal Power	1.320	kW
Max. Speed	3000	RPM

DRIVE TYPE 2010 FEATURES :

I_{NOM_DRIVE} = 10 A

I_{MAX_DRIVE} = 20 A



{ PAIR OF MOTOR POLES, ADDRESS 0 } ← 4

{ RESOLVER SHIFT ANGLE, ADDRESS 1 } ← 0

Supposition : ideal combination between the resolver and the motor.

{ MOTOR THERMOSTAT N/O OR N/C, ADDRESS 2 } ← 0

Thermostat motor normally opened.

{ MAXIMUM MOTOR CURRENT, ADDRESS 3 } ← 21790

With maximum motor current equal at the double of the nominal current.

$$\frac{I_{MAX_MOTOR} = \frac{13.3 \text{ A}}{7FFFh}}{I_{MAX_DRIVE}} = \frac{13.3 \cdot 7FFFh}{20} = 21790 = 551Eh$$

{ NOMINAL MOTOR CURRENT, ADDRESS 4 } ← 10945

$$\frac{NOMINAL_MOTOR = \frac{6.65 \text{ A}}{7FFFh}}{I_{MAX_DRIVE}} = \frac{6.65 \cdot 7FFFh}{20} = 10945 = 2AC1h$$

{ I2T MOTOR, ADDRESS 5 }

{ MAXIMUM SPEED (FOR 10V INPUT), ADDRESS 23 } ← 3243

$$n_{MAX} / 0.925 = 3000 / 0.925 = 3243.2$$

3.2 Installation parameters



3.2.1 Encoder configuration

ENCODER RESOLUTION, ADDRESS 17.

Number of pulses for one revolution, between 1 and 2048 pulses per revolution.
For 1025 to 2048 pulses per revolution, it is an extrapolated resolution.

ENCODER MARKER PULSE WIDTH, ADDRESS 18.

Width of the encoder marker pulse :

- 0 : $\frac{1}{4}$ period of encoder output channel A, gated B\.
- 1 : $\frac{1}{2}$ period of encoder output channel A, gated B\.
- 2 : 1 period of encoder output channel A, gated B\.

Firmware version 2005 or higher :

- 4 : $\frac{1}{4}$ period of encoder output channel A, gated A\.
- 5 : $\frac{1}{2}$ period of encoder output channel A, gated A\.
- 6 : 1 period of encoder output channel A, gated A\.

ENCODER MARKER PULSE POSITION, ADDRESS 19.

Defines the shift between the marker pulse position and the position zero, between $-\frac{1}{2}$ and $+\frac{1}{2}$ turn. To shift of $1/x$ turn enter value $2^{16} * 1/x$.

ENCODER DEAD WINDOW, ADDRESS 34.

Firmware version 2005 or higher :

Width of the dead window for encoder simulation.

- 0 : No dead window
- 1..xx : Dead window width in REV/4096.

Example : The motor position oscillates from $\pm 1/4096$ revolution.

Without dead window : the encoder outputs change continually (± 1 inc.).

With a dead window programmed to 3, the encoder simulation signals will be steady.

This function is useful to reduce vibrations and noises in a system, but be careful that the position precision is also reduced. The position error is not cumulative.



ENCODER MARKER PULSE PERIOD, ADDRESS 15 (OPTION).

Defines the marker pulse period between 1 to 1024 revolutions, with parameter between 0 to 1023.

- 0 : 1 marker pulse each revolution.
- 1..1023 : 1 marker pulse each 2..1024 revolutions.

ENCODER OUTPUT SIGNALS EXAMPLE :

ENCODER MARKER PULSE WIDTH = 1

ENCODER MARKER PULSE POSITION = 0

With a positive speed (display dot off) :

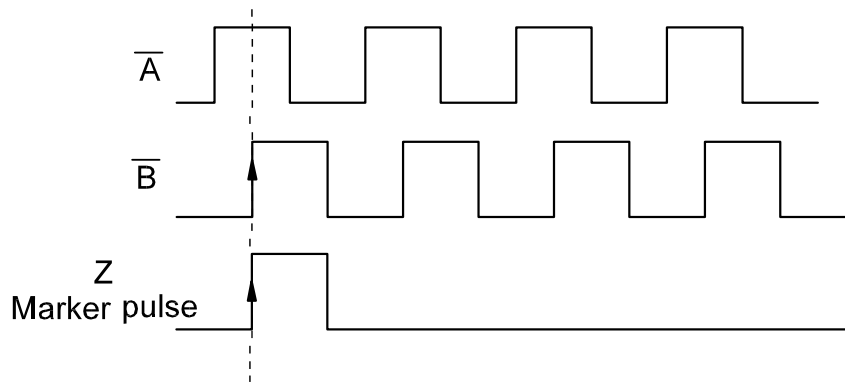

ENCODER INPUT CONFIGURATION, ADDRESS 14 (OPTION).

Options for the encoder input, bit 0 and 1 must be set to change the encoder input configuration :

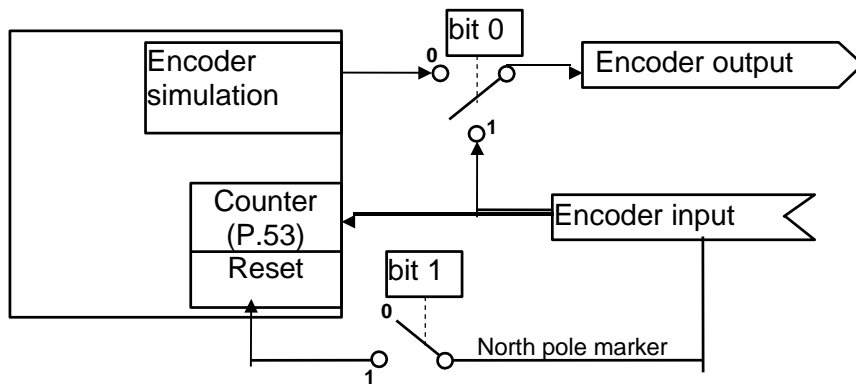



ENCODER INPUT COUNTER, ADDRESS 53 (OPTION).

Value of the encoder input counter. This value is incremented or decremented in accordance with the encoder input signal.

3.2.2 End-switch configuration

Limit end-switch 1 affects the positive speed command, end-switch 2 affects the negative speed command

END LIMIT SWITCHES N/O OR N/C, ADDRESS 24

End-switch 1 and 2 type, normally opened or closed contact :

	0	1
End-switch 1 (bit 0)	normally opened	normally closed
End-switch 2 (bit 1)	normally opened	normally closed

Firmware version 2005 or higher :

Special End-switch function :

Bit 15 = 0 -> End-switches standard function.

Bit 15 = 1 -> End-switch 1 input clears the integral gain of speed loop.

DIRECTION STOP, ADDRESS 25

Stop any direction by changing this value :

	0	1
bit 0	No effect	Positive speed command stopped
bit 1	No effect	Negative speed command stopped

3.2.3 SSI configuration (option)

SSI CYCLIC TRANSMIT PERIOD, ADDRESS 40 (OPTION).

Period for SSI data transmission.



SSI COMMAND, ADDRESS 48 (OPTION).

SSI internal register.

CYCLIC PARAMETER ADDRESS, ADDRESS 49 (OPTION)

SSI internal parameter.

3.2.4 General configuration

MONITORING RELAY RDY/ALA/ENA, ADDRESS 30.

0: Relay ready, the relay is activated at power up and it is deactivated when an alarm is set (Relay alarm inverted).

1: Relay alarm, the relay is activated only when an alarm is set.

Firmware version 2005 or higher :

2: Relay enable, the relay is activated when the power stage of the drive is enabled

ALARM LATCH, ADDRESS 33.

Bit 0 : Alarm 7 Over or under voltage alarm

Bit 2 : Alarm d Earth fault

Bit 4 : Alarm 2 I²t (firmware version 2005 and higher)

Bit 6 : Alarm b Overspeed

Set or clear these bits to activate or deactivate the latch of the corresponding alarm.

EXTERNAL I-LIMIT/LOOP SELECT, ADDRESS 10.

When the « EXTLIMI\ » input (XCOMMAND/PIN 7) is closed to GND, this value becomes the maximum motor current (the value of parameter 3 is disregarded).

When P.10 = 0, the limitation of maximum current by external input is disabled.

Firmware version 2005 or higher :

When P.10 = -1 :

EXTLIMI\ input select the speed or current regulation loop :

EXTLIMI\ = 1 -+ Speed loop.

EXTLIMI\ = 0 -+ Current loop.



MOTOR BRAKE DELAY, ADDRESS 35.

Firmware version 2005 or higher :

0 : No command of motor brake

1..136 : Motor brake is opened (off) when enable input switch ON. When enable input switch OFF, the motor brake is closed (on), speed command is forced to 0 and the power stage is disabled after 1..136 ms.

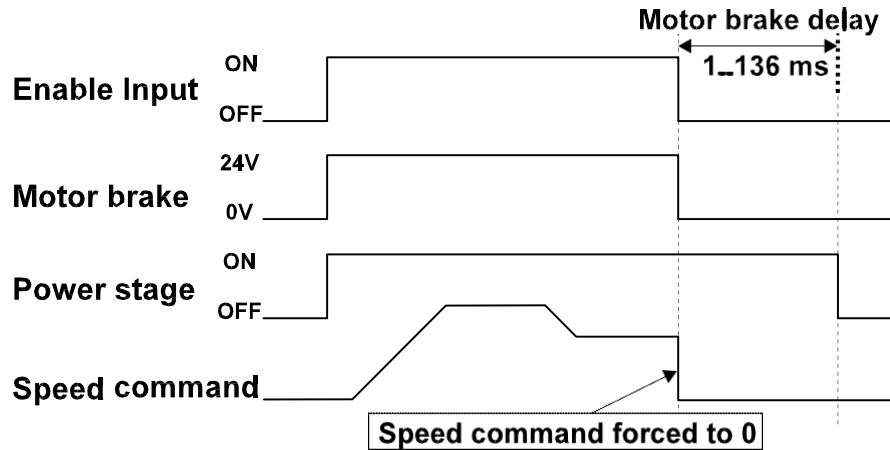

WATCHDOG SOFTWARE COMMUNICATION, ADDRESS 32 .

Watchdog for the SSI link. If the drive does not receive any SSI datas during the defined time (in ms), software watchdog alarm is set (if P.32 = 0: Software watchdog disabled).

Firmware version 2005 or higher :

When this value is different of 0, the watchdog is enabled with the programmed delay for all serial link communications (RS232, RS485 or SSI).

POWER DOWN BACK-UP, ADDRESS 13 (OPTION).

Defines if the drive must save the position at power down (1 for enable this function and 0 for disable).



STATUS DISPLAY 7 SEGMENT VALUE, ADDRESS 51

0: Internal status (the display indicates drive alarms or status)
Change this value to force the display of any information (drive alarms are hidden).

bit7 = DP	bit3 = SEGMENT D
bit6 = SEGMENT A	bit2 = SEGMENT E
bit5 = SEGMENT B	bit1 = SEGMENT F
bit4 = SEGMENT C	bit0 = SEGMENT G

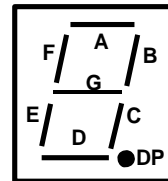

MOTOR REVOLUTIONS COUNTER, ADDRESS 52.

This value can be read for motor position consulting and can be reset at a chosen position.

3.3 Regulation parameters

3.3.1 Configuration

SPEED OR CURRENT LOOP CONTROL, ADDRESS 26.

0 for speed loop and 1 for current loop control. When speedloop is chosen, the command is read as a speed, when currentloop the command is read as a current.

DIGITAL OR ANALOGUE COMMAND, ADDRESS 27.

0 for digital and 1 for analogue.

Digital command :

parameter 50 (Digital command) is read to set the command value.

Analogue command :

Input voltage SPEED IN is converted to set the command value.

DIGITAL COMMAND (SPEED OR CURRENT), ADDRESS 50.

When digital command mode is set, this parameter defines the command value.

ANALOGUE COMMAND OFFSET, ADDRESS 28.

When analogue command mode is chosen, the input offset voltage can be adjusted with this parameter.



COMMAND SLOPE, ADDRESS 29.

Command ramp generator, when this parameter is null, no ramp is performed. When a value different of null is computed, the command edges are limited (for digital and for analogue command), example :

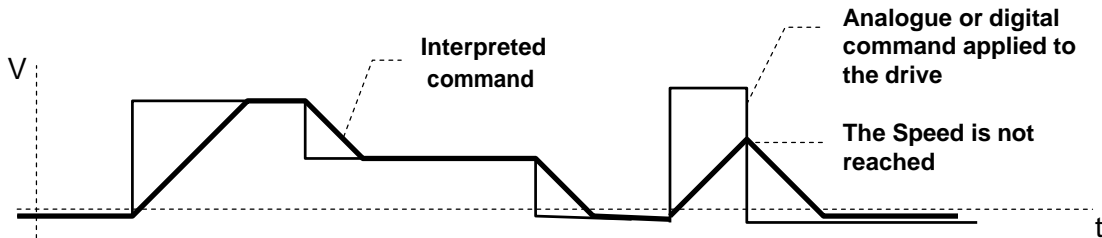

Warning :

If pulse command is applied with a command slope different of zero, it is possible that the wanted speed will be not reached (see second speed cycle of the example).

3.3.2 Current Loop

See also section 4.2 of chapter D (How to set the current loop parameters, page 65).

PID CURRENT LOOP CONTROLLER :

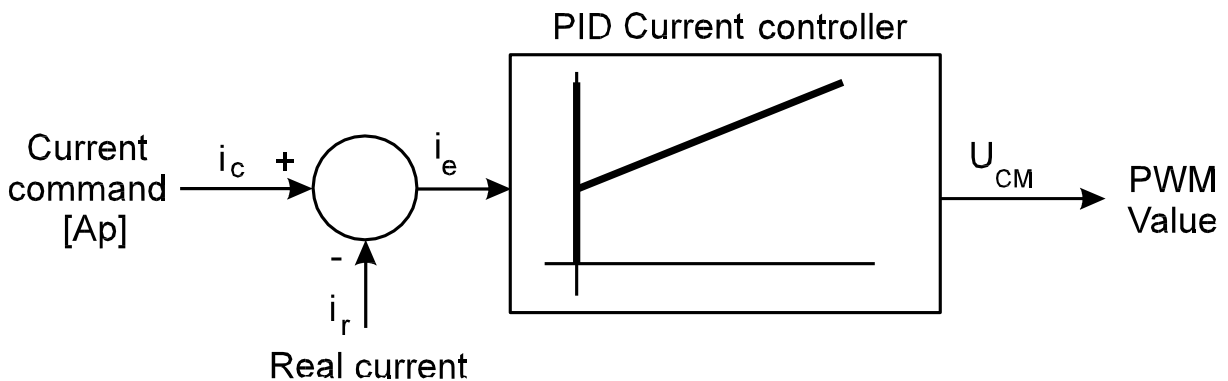

**DIGITAL PID EQUATION :**

$$U_{CM} = Kp \cdot i_{e[N]} + Ki \cdot \sum_{i=0}^N (i_{e[i]} \cdot \Delta T) + Kd \frac{(i_{e[N]} - i_{e[N-1]})}{\Delta T}$$

$i_{e[N]}$: Last sample

ΔT : Sampling time

The drive values are obtained with the following equations :

CURRENT LOOP PROPORTIONAL GAIN (Kp), ADDRESS 6.

2000 series : $Kp = \frac{P_{CURRENT}}{\hat{I}_{MAX}}$ [V/A]

4000 series : $Kp = \frac{\sqrt{3} \cdot P_{CURRENT}}{\hat{I}_{MAX}}$ [V/A]

$P_{CURRENT}$ = Parameter 6

CURRENT LOOP INTEGRAL GAIN (Ki), ADDRESS 7.

2000 series : $Ki = \frac{7500 \cdot I_{CURRENT}}{\hat{I}_{MAX}}$ [V/As]

4000 series : $Ki = \frac{7500 \cdot \sqrt{3} \cdot I_{CURRENT}}{\hat{I}_{MAX}}$ [V/As]

$I_{CURRENT}$ = Parameter 7



CURRENT LOOP DIFFERENTIAL GAIN (Kd), ADDRESS 8.

2000 series :
$$Kd = \frac{133 \cdot 10^{-6} \cdot D_{CURRENT}}{\hat{I}_{MAX}} \quad [Vs/A]$$

4000 series :
$$Kd = \frac{133 \cdot 10^{-6} \sqrt{3}}{D_{CURRENT} \hat{I}_{MAX}} \quad [Vs/A]$$

$D_{CURRENT}$ = Parameter 8

3.3.3 Speed Loop

See also section 4.3 of chapter D (How to set the speed loop parameters, page 67).

PID SPEED LOOP CONTROLLER :

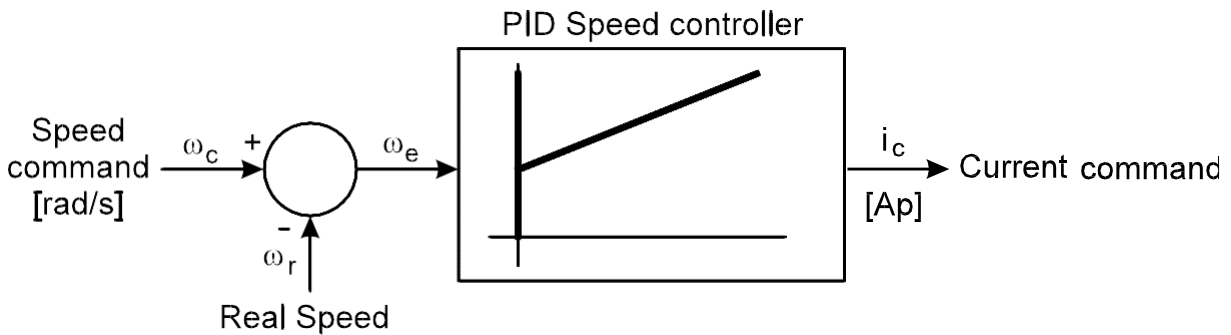

DIGITAL PID EQUATION :

$$i_c = Kp \cdot \omega_{e[N]} + Ki \cdot \sum_{i=0}^N (\omega_{e[i]} \cdot \Delta T) + Kd \frac{(\omega_{e[N]} - \omega_{e[N-1]})}{\Delta T}$$

$\omega_{e[N]}$: Last sample

ΔT : Sampling time



The drive values are obtained with the following equations :

SPEED LOOP PROPORTIONAL GAIN, ADDRESS 20.

$$Kp = 4,92 \cdot 10^{-6} \cdot \hat{I}_{MAX} \cdot P_{SPEED} \text{ [}\hat{A}\text{/rad]}$$

P_{SPEED} = Parameter 20

SPEED LOOP INTEGRAL GAIN, ADDRESS 21.

$$Ki = 3,73 \cdot 10^{-2} \cdot \hat{I}_{MAX} \cdot I_{SPEED} \text{ [}\hat{A}\text{/rad]}$$

I_{SPEED} = Parameter 21

SPEED LOOP DIFFERENTIAL GAIN, ADDRESS 22.

$$Kd = 6,5 \cdot 10^{-10} \cdot \hat{I}_{MAX} \cdot D_{SPEED} \text{ [}\hat{A}\text{/(rad}\cdot\text{s)}]$$

D_{SPEED} = Parameter 22

4. How to set the parameters



To set the parameters, you need the Windows User software, refer to the section 2 of chapter B.

Resume of Windows User functions for setting the parameters :

Main window :

Regulation loop icon :



Store parameter icon :



or key F2

Scope icon :



Automatic command icon :



Automatic command mode window :

Single Pulse mode button :

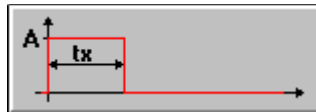

Single-polarity periodical mode button :

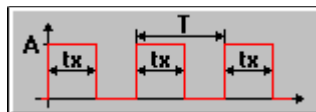

Square edge wave form button :





4.1 How to set the resolver shift angle parameter

This operation should be done only when the resolver shift angle is unknown. In this case, the setting procedure is as follows :

D A)

Click on the « Regulation loop » icon and click on the « M » (motor) button in the « Regulation loop » window.

D B)

Set the « Maximum motor current » to 25% of the Nominal motor current in the « Motor features » window.

D C)

Click on the « Speed command » button in the « Regulation loop » window. Then click on the « Single-polarity periodical pulse mode » button in the « Automatic command mode » window.

Enter : A = 120 rpm
 tx = 200 ms
 T = 200 ms

And click on the « Run » button.

D D)

Click on the « Resolver » button in the « Regulation loop » window and Enable the drive.

D E)

Search the « Resolver shift angle » range where the motor is running at 120 rpm.

The optimal value of « Resolver shift angle » is in the middle of the above mentioned range.

Functioning diagram depending of the resolver shift angle setting :

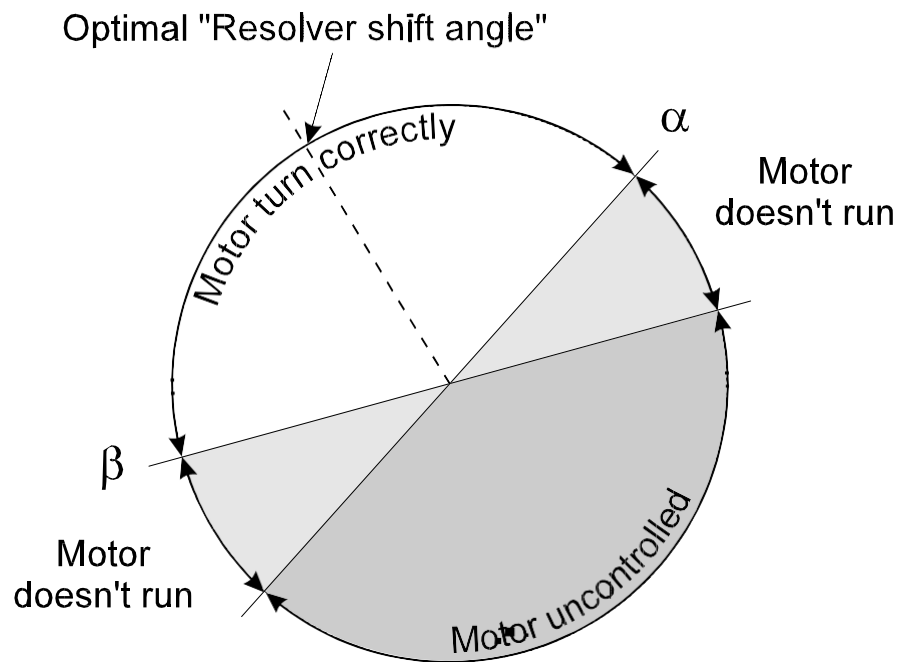

The optimal value of « Resolver shift angle » is given by :

$$\text{Optimal resolver shift angle} = \frac{\alpha + \beta}{2}$$

D F)

Disable drive, store the optimal « Resolver shift angle » by striking F2.



4.2 How to set the current loop parameters

The procedure for the manual setting is as follows :

D A)

Click on the « Regulation loop » icon and select the « current loop » control.

D B)

Click on the « PID » button of the current controller and set :

- Current loop Integral gain to 0.
- Current loop Differential gain to 0.
- Phase advance to 0.
- Maximum motor current to the max. value.

D C)

Click on the « Resolver » button and set the « Resolver Shift angle » to its optimal value added or subtracted by 90°.

D D)

Click on the « Current Command » button. Then click on the single pulse mode button in the « Automatic command mode » window.

Enter : A = Max. peak value of the motor
 tx = 100 ms
 select the square edge wave form.

D E)

Click on the « scope function » icon and select :

- Channel 1 : Current command (Parameter 182)
- Channel 2 : Instant current (Parameter 67)
- Suggested configuration :
 - Time scale : 1 ms/div
 - Vertical scale channel 1 and 2 : $\approx I_{DRIVE\ NOM} / div$

D F)

Enable the drive and click on the « Run » button in the « Automatic command mode » window.



D G)

Optimize the « Current loop Proportional Gain » (K_p). The typical value of K_p is 100.

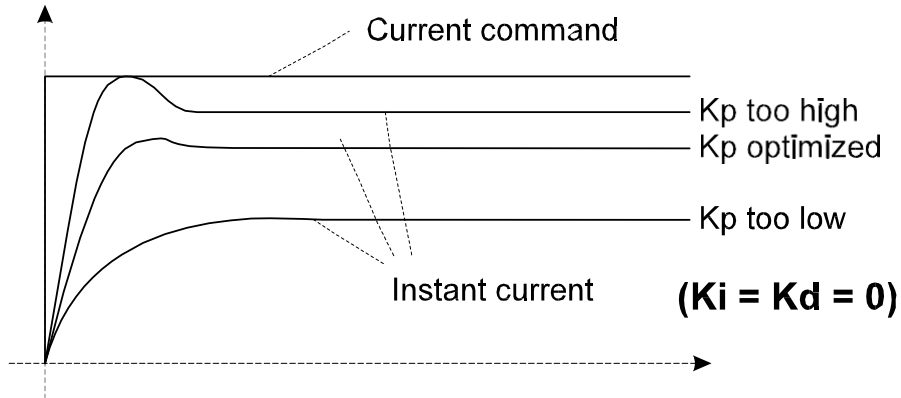

Store the optimal value of K_p by striking F2.

D H)

Optimize the « Current loop Integral Gain » (K_i). The typical value of K_i is 5.

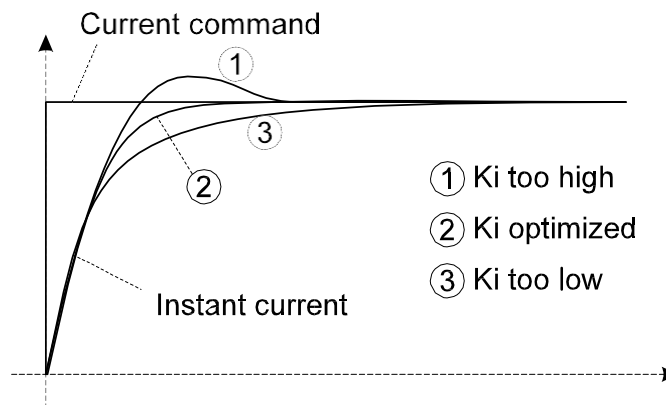

Store the optimal value of K_i by striking F2.

D I)

The « Current loop Differential Gain » (K_d) remains in most applications at 0.

D J)

Set the « Resolver Shift angle » again to its optimal value and store by striking F2.



4.3 How to set the speed loop parameters

The procedure is as follows :

D A)

Click on the « Regulation loop » icon and select the « speed loop » control.

D B)

Click on the « PID » button of the Speed controller and set :
speed loop Integral gain to 0.
speed loop Differential gain to 0.
maximum speed (for 10V input) at max motor speed

D C)

Click on the « Speed command » button.
Then click on the « single pulse mode » button in the « Automatic command mode » window.

Enter : A = 1/5 of the application speed.
 tx = 200 ms (for example).
 select the square edge wave form.

D D)

Click on the « scope function » icon and select :

- Channel 1 : Digital command (Parameter 50)
- Channel 2 : Instant speed (Parameter 68)
- Suggested configuration :
 - Time scale : 16 ms/div (with free running motor)
 - Vertical scale channel 1 and 2 : $\approx 1/10$ appl. speed / div

D E)

Enable the drive and click on the « Run » button in the « Automatic command mode » window.



D F)

Optimize the « Speed loop Proportional Gain ». The typical value is 5000. Two methods allow the setting of this gain.

D F1)

Method without the « Scope function »

Vary the « Speed loop Proportional Gain » around the typical value. The motor whistle and oscillate when the gain is too high. In this case, decrease the gain to obtain a good behaviour (stability) in the whole speed range.

Store this optimal gain by striking F2.

D F2)

Method with the « scope function »

The respond at a single speed step command looks as follows (with free running motor) :

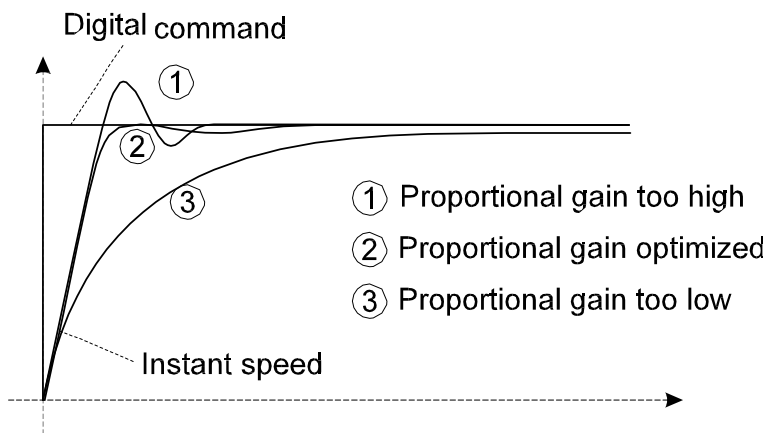

Store the optimal gain by striking F2.

D G)

Optimize the « speed loop Integral Gain ».

The typical value is 50.

Two methods allow the setting of this gain.



D G1)

Method without the « Scope function »

The « Speed loop Integral Gain » is too low when the axis moves « step by step » with a small speed command. The motor axis is too smooth.

This gain is too high when the motor axis oscillates with a small speed command.

This gain is optimized when the motor axis doesn't oscillates and when the stiffness of the motor axis is sufficient to avoid its motion « step by step ».

D G2)

Method with the « Scope function »

The respond at a single speed step command looks as follows :

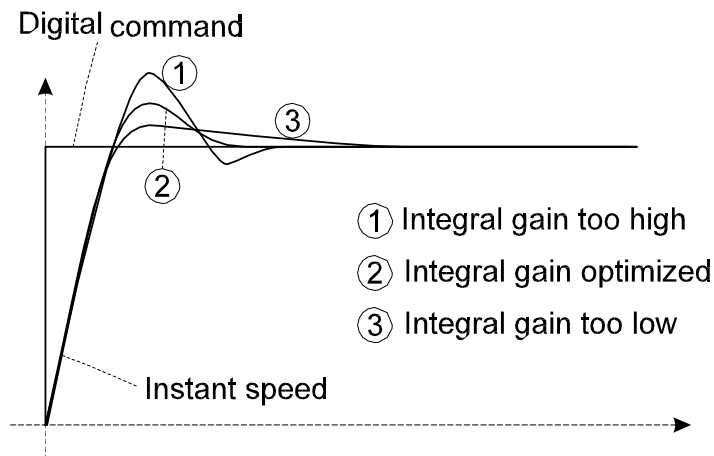











Store the optimal gain by striking F2.

D H)

The « speed loop Differential Gain » remains in most applications at 0.

5. Trouble shooting



Display	Trouble shooting
	<p>I²t reached alarm.</p> <ul style="list-style-type: none"> • Check Resolver shift angle Parameter (P1). • Check I2t motor Parameter (P5). • Check drive capacity for the application.
	<p>Motor thermostat alarm.</p> <ul style="list-style-type: none"> • Motor overload. • Motor thermal switch disconnected or bad connected. • Check Motor Thermostat n/o or n/c parameter (P2).
	<p>Drive internal over temperature alarm (> 80°C).</p> <ul style="list-style-type: none"> • Drive overloaded. • Drive cooling deficient.
	<p>Resolver alarm.</p> <ul style="list-style-type: none"> • Resolver wiring or link failure. • Resolver failure. • Check resolver type see section 3.7 of chapter A.
	<p>Power module fault (over I or over temperature).</p> <ul style="list-style-type: none"> • Switch off and check motor, look for short circuits between motor phases.
	<p>Over or under voltage alarm</p> <ul style="list-style-type: none"> • Check main supply input voltage L1, L2 and L3.
	<p>Software watchdog.</p> <ul style="list-style-type: none"> • Check time-out, Watchdog software communication parameter (P32). • Check serial link.
 appears during 1 second on display.	<p>Over current alarm (125% of maximum drive current reached).</p> <ul style="list-style-type: none"> • Bad regulation parameters, refer to « How to set the current loop parameters », section 4.2 of chapter D. • Check Power supply voltage, 3 x 230V for 2000 series or 3 x 400V for 4000 series.
	<p>Over speed alarm (125% of max. motor speed reached)</p> <ul style="list-style-type: none"> • Check Maximum speed (for 10V input) parameter (P23) value.
	<p>Motor link fault.</p> <ul style="list-style-type: none"> • Motor connection failure.
	<p>Earth fault.</p> <ul style="list-style-type: none"> • Look for a possible short circuit between earth and motor phases.



Display	Trouble shooting
	Parameter not OK (wrong checksum of stored parameter) <ul style="list-style-type: none"> • Check parameter and store parameters.
	Firmware not OK (only after an update of the firmware) <ul style="list-style-type: none"> • Reload firmware.
	Hardware incompatibility. <ul style="list-style-type: none"> • The firmware is incompatible with drive hardware.

Trouble	Possible cause
Display 0 but the motor doesn't move when a speed command is applied	<ul style="list-style-type: none"> • End-limit switch enable • Max. drive current too low (P3) • Motor brake engaged
The motor jump to a position and stay blocked.	<ul style="list-style-type: none"> • Pair of motor Poles parameter (P0) misadjusted. • Motor wiring on terminal U, V, W not in the correct sequence.
Motor noisy	<ul style="list-style-type: none"> • Check resolver cable • Check separation between resolver and motor cable (also inside the motor). • Check earth link • Check regulation parameters.
No link with Drive (Drive Offline appears in User software while the drive is connected to the computer).	<ul style="list-style-type: none"> • Check AXIS SELECTOR position (if present) : RS232 : Position 0 RS485 : Position 1-15 The drive must be resetted to enable a change of the Axis selector position (for more information about Axis selector, see page 43). • Check link cable. • Check Serial Port number in User software.
Firmware upgrade cannot be performed.	<ul style="list-style-type: none"> • The firmware upgrade is possible only with RS232 link. • Check RS232 link



These instructions have been written and checked to the best of our knowledge and belief. However, Servo Dynamics, Corp. will not be liable for errors and reserves the right for changes at any time without notice.



CHAPTER E ASYNCHRONOUS MOTOR

Drive series 2000 and 4000 are able to control asynchronous motors. To perform this, a few conditions are required :

- Firmware version must include regulation for asynchronous motor (test version : 2601).
- Compatible Windows user (Version 1.20 or higher) for parameters settings.
- Asynchronous motor must have a resolver or an encoder feedback.

This chapter describes only special parameters suitable to asynchronous motor. Other parameters have the same functions defined previously in this manual.

1. Change of motor and feedback type

Important :

The change of motor and feedback type is possible only with Windows user version 1.20 or higher.

A double click in the motor/feedback box included in the toolbar of the Windows user enable a Window for the selection of motor and feedback type. This Window can be also called by the « Motor type » item of the « Configuration » menu.



If the firmware version does not include the possibility to change motor or feedback type, the selection are automatically disabled.

When the motor or the feedback type is changed, the parameter list is also updated in accordance with selected motor and feedback .

2. Special parameters for asynchronous motors



Addr.	St.	R/W	Unit	Limits	Description
9		R/W	$\frac{100}{7FFF_h}$ %	0..15%	Slip factor
11		R/W	-	0..1	Cosinus phi
54		R/W	1/revolution	0..7FFFh	Encoder input resolution
55		R/W	0.925 RPM	8000h..7FFFh	Field weakening speed
65		R			Alarm register
		Bit	Description		Drive Display
		10	Overspeed asynchronous		<input type="checkbox"/>

SLIP FACTOR, ADDRESS 9.

Slip factor defined the ratio : $\frac{Speed_{synchronous} - Speed}{Speed_{synchronous}}$

Standard value=1..7%, usually, 4% is a good value.

COSINUS PHI, ADDRESS 11.

The cosinus phi is given from the manufacture, usually, a value between 0.8 and 0.9.

2.1 Field weakening

FIELD WEAKENING SPEED, ADDRESS 55.

If field weakening is needed, this parameter must be set to the speed value the field weakening must begin.

2.2 Asynchronous alarm



Asynchronous overspeed, set when the motor speed is higher than 133% of synchronous speed (only if field weakening is disabled).



2.3 Feedback type

Two feedback types can be used with asynchronous motor :

- Resolver
- Encoder

2.3.1 Resolver feedback

With a resolver feedback, the settings are identical as describe for brushless motors. The Resolver shift angle is ignored.

2.3.2 Encoder feedback

The encoder must be **external powered**.

The motor encoder must be wired to the encoder inputs of the XENCODER connector (see section 0 of chapter D, 1.3.3 XENCODER wiring).

With encoder feedback, the encoder simulation is disabled, the input is directly wired on encoder output. All parameters for the configuration of encoder simulation are not used.

ENCODER INPUT RESOLUTION, ADDRESS54.

The encoder resolution (number of pulse for one revolution) must be set in this parameter.



Index

A

Add-on boards	
SDC Profile.....	15
MKS Synchro-Control.....	16
Quin Servonet	16
Adj.factor sine/cosine	26
Alarm.....	30; 47
Alarm latch.....	28; 55
Analogue command offset.....	28; 57
Asynchronous motor.....	73
Alarms	74
Change of feedback type.....	73
Change of motor type.....	73
Cosinus phi.....	74
Encoder feedback.....	75
Encoder resolution.....	75
Field weakening speed	74
Resolver feedback.....	75
Slip Factor	74
Special parameters.....	74
Axis selector.....	43

B

Baudrate.....	7
Braking power	8

C

Cable	
Connections.....	<i>See Wiring</i>
Length	35
Crossection	35
Command Slope.....	28; 58
Current loop	
Differential gain.....	26; 60
Integral gain.....	26; 59
Proportional gain.....	26; 59

D

Digital command.....	29; 57
Digital or Analogue command	27; 57
Direction stop.....	27; 54
Display	
Alarms	47
Indications	46
Segment value.....	29; 57
Warnings	47

DOS User	19
----------------	----

E

Electrical data	8
Encoder	
Dead window	28; 52
Input configuration.....	26; 53
Input counter.....	29; 54
Marker pulse position	27; 52
Marker pulse width	27; 52
Resolution.....	27; 52
End limit switches	27; 54
External I-limit/Loop select	26; 55

F

Filter.....	15
Fuses.....	14

I

I ² t motor	26; 49
Installation Large	
11	
Medium	10
Small.....	9

M

Maximum speed	27; 50
Monitoring Relay Rdy/Ala/Ena.....	28; 55
Motor	
Asynchronous	<i>See Asynchronous motor</i>
Cable	35
Instantaneous current.....	31
Instantaneous speed	31
Maximum current.....	26; 48
Maximum speed	27; 50
Motor brake delay	28; 56
Motor brake wiring.....	44
Motor I ² t.....	26; 49
Nominal current	26; 48
Pair of motor poles	26; 48
Phases.....	45
Revolutions counter.....	29; 57
Thermostat.....	26; 38; 48
XMOTOR wiring	44



O

Option list 15
Outlines
 Large 11
 Medium 10
 Small 9

P

Parameters 62
 Description 25
 Global list 26
 How to set current loop parameters 65
 How to set Resolver shift angle 63
 How to set the speed loop parameters 67
Phase advance 26
Phoenix clamp 12
Profile 15

R

Resolver 13
 wiring 38
Resolver shift angle 26; 64

S

Serial link
 Dialogue examples 24
 Dialogue protocol 23
Slip Factor (asynchronous motor) 74
Speed loop
 Differential gain 27; 61
 Integral gain 27; 61
 Proportional gain 27; 61
Speed or Current loop control 27
Status 30
Supply Voltage 7

T

Trouble shooting 70

U

User software
 2000U.EXE (DOS software) 19
 2000WU.EXE (Windows software) 20
 FPRGU.EXE (DOS software) 18

W

Warnings 47
Watchdog software 28; 56
Weight 7
Windows User 20
Wiring
 Control unit 37
 Global plan 36
 XCOMMAND 39
 XENCODER 40
 XMOTOR 44
 XRESOLVER 38
 XSERIAL 232 41
 XSERIAL 485 41

**DRIVE 2000/4000, INSTRUCTION MANUAL EVOLUTION****Modifications and news compared with December 1998 manual :**

CHAPTER	SECTION	PAGE	NEW	MODIF	DESCRIPTION
A	1	5		X	Text adapted for asynchronous motor.
A	3.1	7		X	Storage temperature : « -20 to + 70 » ⇒ « -25 to +55 »
A	3.1	7		X	OFF-Trip threshold of overvoltage : 700 VDC ⇒ 690 VDC OFF-Trip threshold of undervoltage : 295 VDC ⇒ 395 VDC ON-Trip threshold of undervoltage : 280 VDC ⇒ 380 VDC
A	3.1	7	X		Medium weight added
A	3.1	7		X	« Rated power dissipation during bracking... » line deleted (page 8 table gives the correct values for all types of drives).
A	3.1	7		X	Incremental encoder simulation : 1 to 1024 (2048)
A	3.2	8	X		Medium electrical and bracking data added
A	3.4	10	X		Medium outlines added.
A	3.3	9-12		X	Mechanical description changed : details added in views and installation plans added.
A	3.8	14		X	Stegmann encoder not more in development.
A	4	15	X		4020 DC BUS fuse type : URGA ⇒ URGB.
A	4	15	X		Medium fuses added.
A	0	15	X		New option : AUXILIARY 24V SUPPLY.
A	6	16		X	MKS IR116 and IR117 board added. Future product : « CAN-BUS interface » deleted.
A	7	17	X		External modules, RS232<->RS485 converter description.
B	0	21		X	Use of 2000WU.exe : Help can be called only by the menu or by F1 key (icon « ? » removed from toolbar since version 1.20 of 2000wu).
B	0	21		X	Update firmware with 2000WU.exe procedure : Change of messages and menus texts (analogy with 2000WU was wrong).
C	0	28		X	P.23, Maximum speed parameter Example : 3200 ⇒ 2960 instead of 3200 ⇒ 2880
C	0	31		X	P.68, Instantaneous motor speed Example : 2667 ⇒ 2467 instead of 2667 ⇒ 2400
D	0	35	X		Note added about PE conductor : PE terminal permanently connected to the earth and protective conductor cross-section >10mm ² Cu.
D	0	36	X		DC BUS +/- and DC BUS CTRL terminals are not present when drive is equipped with « EMC filter » option.
D	0	37		X	XSERIAL 485 indicated as optional
D	0	39		X	Note 2) correction : the inhibit or the free of the movement by end-limit switches, depend of parameter 24 configuration.
D	0	43		X	When drive is programmed with a monitor version 300 _h (or higher), the firmware update is also possible by RS485 (the parameter 72 indicates the monitor version)
D	0	50		X	P.23, Maximum speed parameter : conversion error 3000/0.925=3243.2 instead of 3333.3
D	0	53		X	P.15, encoder marker pulse period : more details in description
D	3.2.4	56		X	Detail added : « When P.32 = 0 : Software watchdog disabled »
D	3.3.2	58		X	Current loop equation and gain PID corrections
D	3.3.3	60		X	Speed loop equation correction

LAST MODIFICATION : 10-99.