

IG 23 - C with HE Feedback

Model Numbering

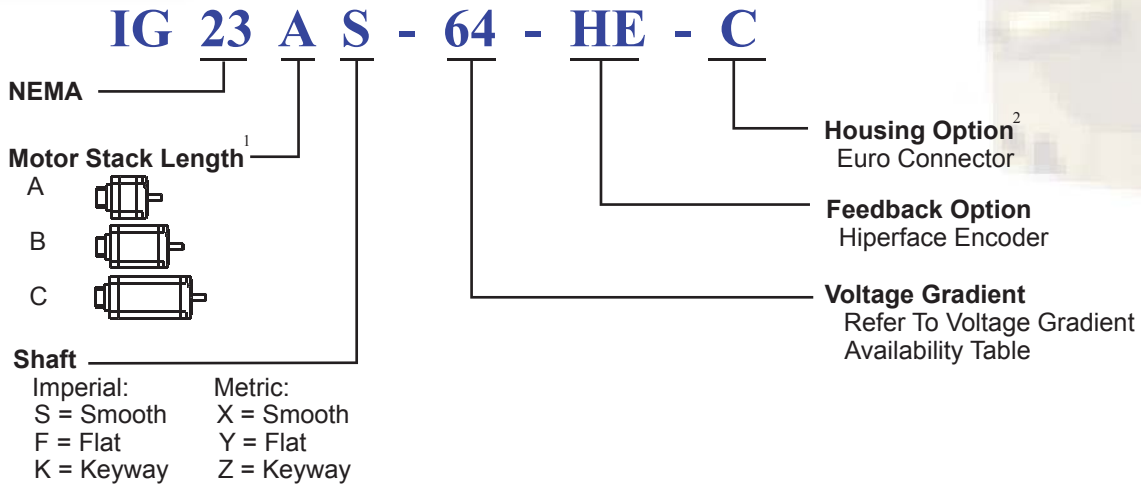

1. Refer to Dimensions for the exact length and shaft options
2. All the motors are rated IP64 and by adding front shaft seal it's rating becomes IP65

Voltage Gradient

Voltage Constant K_E (V/kRPM)	8	11	16	22	32	44	64	88	130	180
Frame Size IG 23										

Performance Curves

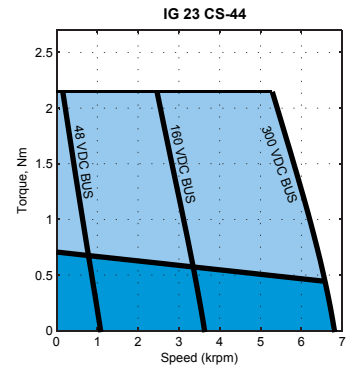
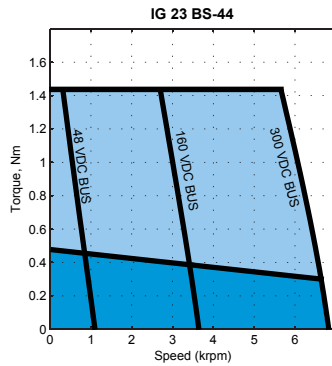
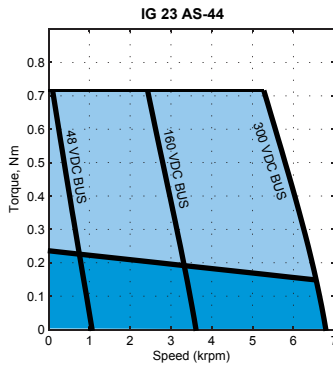

Contact factory for torque-speed curves of other motors

IG 23 - C with HE Feedback

Motor Specification

NEMA 23																		
Index	Model Number	Weight		Torque Constant (Peak) (L2L)		Voltage Constant	Cont. Stall Torque		Cont. stall current	Peak Stall Torque		Peak Stall Current	Max BEMF (Peak) (L2L)	Max Speed	L-to-L Resistance	L-to-L Inductance	Rotor Inertia	
		W		K _T		K _E	T _{cs}		I _{cs}	T _P		I _P	U _{max}	n _{max}	R	L	J	
		kg	lb	Nm/A	lb-in/A	V/krpm	Nm	lb-in	A	Nm	lb-in	A	V	rpm	Ohms	mH	kg-cm ²	lb-in-sec ²
13	IG 23 AS - 8	0.62	1.37	0.09	0.78	8.00	0.24	2.12	2.72	0.72	6.37	8.16	64.00	8000	0.60	0.72	0.30	0.00027
14	IG 23 BS - 8	0.96	2.12	0.09	0.78	8.00	0.48	4.25	5.44	1.44	12.75	16.32	64.00	8000	0.28	0.35	0.60	0.00053
15	IG 23 CS - 8	1.20	2.65	0.09	0.78	8.00	0.72	6.37	8.16	2.16	19.12	24.48	64.00	8000	0.21	0.24	0.90	0.00080
16	IG 23 AS - 11	0.62	1.37	0.12	1.07	11.00	0.24	2.12	1.98	0.72	6.37	5.94	88.00	8000	1.40	1.90	0.30	0.00027
17	IG 23 BS - 11	0.96	2.12	0.12	1.07	11.00	0.48	4.25	3.96	1.44	12.75	11.87	88.00	8000	0.55	0.75	0.60	0.00053
18	IG 23 CS - 11	1.20	2.65	0.12	1.07	11.00	0.72	6.37	5.94	2.16	19.12	17.81	88.00	8000	0.45	0.60	0.90	0.00080
19	IG 23 AS - 16	0.62	1.37	0.18	1.56	16.00	0.24	2.12	1.36	0.72	6.37	4.08	128.00	8000	2.65	3.20	0.30	0.00027
20	IG 23 BS - 16	0.96	2.12	0.18	1.56	16.00	0.48	4.25	2.72	1.44	12.75	8.16	128.00	8000	1.00	1.35	0.60	0.00053
21	IG 23 CS - 16	1.20	2.65	0.18	1.56	16.00	0.72	6.37	4.08	2.16	19.12	12.24	128.00	8000	0.78	1.10	0.90	0.00080
22	IG 23 AS - 22	0.62	1.37	0.24	2.15	22.00	0.24	2.12	0.99	0.72	6.37	2.97	176.00	8000	5.90	9.30	0.30	0.00027
23	IG 23 BS - 22	0.96	2.12	0.24	2.15	22.00	0.48	4.25	1.98	1.44	12.75	5.94	176.00	8000	2.20	2.90	0.60	0.00053
24	IG 23 CS - 22	1.20	2.65	0.24	2.15	22.00	0.72	6.37	2.97	2.16	19.12	8.90	176.00	8000	1.80	2.40	0.90	0.00080
25	IG 23 AS - 32	0.62	1.37	0.35	3.12	32.00	0.24	2.12	0.68	0.72	6.37	2.04	256.00	8000	15.20	18.20	0.30	0.00027
26	IG 23 BS - 32	0.96	2.12	0.35	3.12	32.00	0.48	4.25	1.36	1.44	12.75	4.08	256.00	8000	6.20	7.10	0.60	0.00053
27	IG 23 CS - 32	1.20	2.65	0.35	3.12	32.00	0.72	6.37	2.04	2.16	19.12	6.12	256.00	8000	4.60	5.70	0.90	0.00080
28	IG 23 AS - 44	0.62	1.37	0.49	4.29	44.00	0.24	2.12	0.49	0.72	6.37	1.48	352.00	8000	28.50	35.60	0.30	0.00027
29	IG 23 BS - 44	0.96	2.12	0.49	4.29	44.00	0.48	4.25	0.99	1.44	12.75	2.97	352.00	8000	11.50	14.10	0.60	0.00053
30	IG 23 CS - 44	1.20	2.65	0.49	4.29	44.00	0.72	6.37	1.48	2.16	19.12	4.45	352.00	8000	9.10	12.30	0.90	0.00080
31	IG 23 AS - 64	0.62	1.37	0.71	6.25	64.00	0.24	2.12	0.34	0.72	6.37	1.02	512.00	8000	67.20	80.90	0.30	0.00027
32	IG 23 BS - 64	0.96	2.12	0.71	6.25	64.00	0.48	4.25	0.68	1.44	12.75	2.04	512.00	8000	26.90	33.10	0.60	0.00053
33	IG 23 CS - 64	1.20	2.65	0.71	6.25	64.00	0.72	6.37	1.02	2.16	19.12	3.06	512.00	8000	21.30	27.60	0.90	0.00080
34	IG 23 AS - 88	0.62	1.37	0.97	8.59	88.00	0.24	2.12	0.25	0.72	6.37	0.74	704.00	8000	107.00	134.50	0.30	0.00027
35	IG 23 BS - 88	0.96	2.12	0.97	8.59	88.00	0.48	4.25	0.49	1.44	12.75	1.48	704.00	8000	43.30	54.50	0.60	0.00053
36	IG 23 CS - 88	1.20	2.65	0.97	8.59	88.00	0.72	6.37	0.74	2.16	19.12	2.23	704.00	8000	35.80	45.20	0.90	0.00080
37	IG 23 AS - 130	0.62	1.37	1.43	12.69	130.00	0.24	2.12	0.17	0.72	6.37	0.50	1,040.00	8000	170.20	212.50	0.30	0.00027
38	IG 23 BS - 130	0.96	2.12	1.43	12.69	130.00	0.48	4.25	0.33	1.44	12.75	1.00	1,040.00	8000	68.50	86.84	0.60	0.00053
39	IG 23 CS - 130	1.20	2.65	1.43	12.69	130.00	0.72	6.37	0.50	2.16	19.12	1.51	1,040.00	8000	56.70	71.80	0.90	0.00080
40	IG 23 AS - 180	0.62	1.37	1.98	17.57	180.00	0.24	2.12	0.12	0.72	6.37	0.36	1,440.00	8000	307.40	406.50	0.30	0.00027
41	IG 23 BS - 180	0.96	2.12	1.98	17.57	180.00	0.48	4.25	0.24	1.44	12.75	0.73	1,440.00	8000	131.00	166.10	0.60	0.00053
42	IG 23 CS - 180	1.20	2.65	1.98	17.57	180.00	0.72	6.37	0.36	2.16	19.12	1.09	1,440.00	8000	101.00	136.70	0.90	0.00080

L2L: Line-to-Line

IG 23 - C with HE Feedback

Motor Drawing

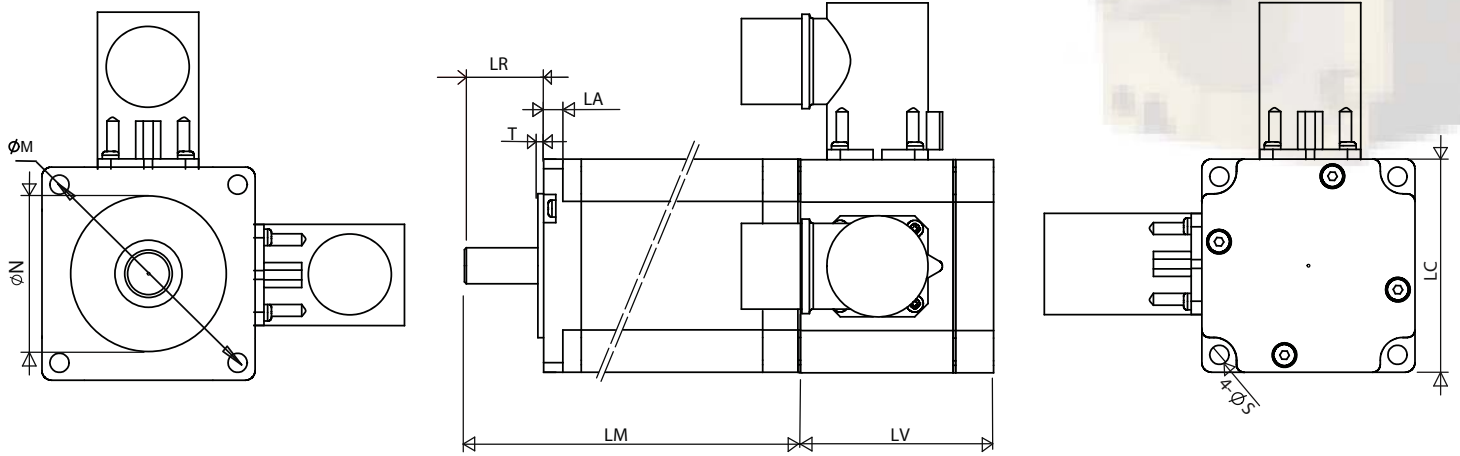

FRONT SHAFT OPTIONS
 (1) SMOOTH SHAFT, AS SHOWN IN THE VIEWS
 (2) KEYWAY SHAFT
 (3) FLAT SHAFT

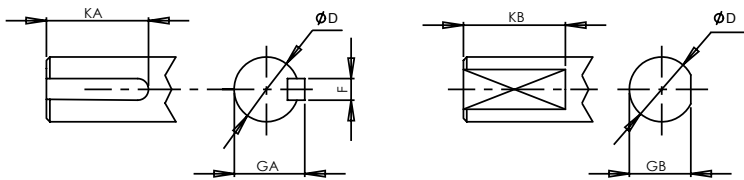

NOTE:
 ALL THE MOTORS ARE RATED IP64 AND BY ADDING FRONT
 SHAFT SEAL, IT'S RATING BECOMES IP65

Units: inches (mm)

IG	LM	LV	LA	T	LR	LC	N	S	M	
23	A	2.795 (71)	2.00 (50.7)	0.20 (5.1)	0.060 (1.5)	0.825 (21)	2.220 (56.4)	1.500 ⁰ _{-0.002} (38.10 ⁰ _{-0.05})	0.200 (5.1)	2.625 (66.68)
	B	3.858 (98)								
	C	4.921 (125)								

Imperial Shaft Option (S/F/K), Units: Inches							Metric Shaft Option (X/Y/Z), Units: mm					
IG	D	F	GA	KA	GB	KB	D	F	GA	KA	GB	KB
23	0.3750 ⁰ _{-0.0005}	0.0938 ⁰ _{-0.001}	0.416 ⁰ _{-0.002}	0.50	0.340 ⁰ _{-0.004}	0.50	10 ⁰ _{-0.013}	3 ⁰ _{-0.025}	11.2 ⁰ _{-0.051}	15	9.0 ⁰ _{-0.1}	15.0

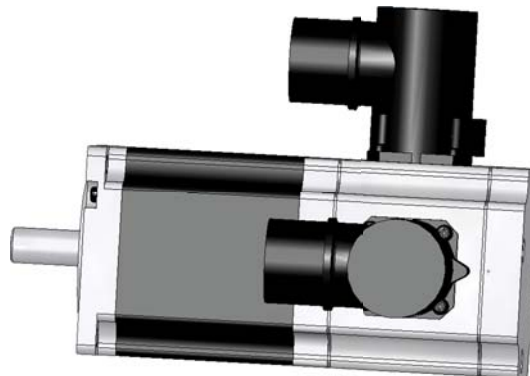

Mar, 08, 06

IG 23- C with HE Feedback

Power Supply

Non Brake Power Wiring Diagram

LEOB 06C PIN	Definition
1	U
2	V
3	GND
4	-
5	-
6	W

Power Connector, Customer View

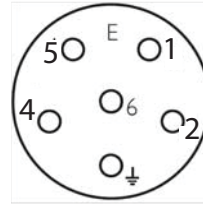

Connector:
LEOB06CMRSN000
PIN Arrangement

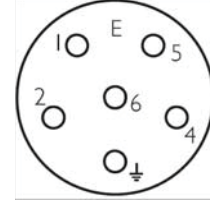

Mating Connector:
LPRA06BFRDN170
PIN Arrangement

Hiperface Encoder

Hiperface Encoder Data SKS 36, SKM 36

Parameter	Values
# of sine/cosine periods per revolution	128
Code type for the absolute value	Binary
Total number of steps (single SKS)	4,096
Output frequency for sine/cosine signals	0 .. 65 kHz
Operating speed (SKS)	12,000 min ⁻¹
Working temperature range	+ 5 ... + 110°C
Operating voltage range	7 ... 12 v
Recommended supply voltage	8 v
Max. operating current, no load	60 mA
Interface signals	
Process data channel=SIN, REFSIN, COS, REFCOS	Analogue, differential
Parameter channel = RS 485	Digital

Hiperface Encoder Connector Wiring Diagram

SFMB 12T PIN	Wire Code	Definition
1	ORN/BLK	SIN +
2	BLK/ORN	SIN -
3	BLU/BLK	DATA +
4	BLK/BLU	DATA -
5	BLK/WHT	GND
6	RED/WHT	THERMISTOR 1
7	WHT/RED	THERMISTOR 2
8	WHT/BLK	+VDC
9	N.C.	-
10	BRN/BLK	COS +
11	N.C.	-
12	BLK/BRN	COS -

Encoder Connector, Customer View

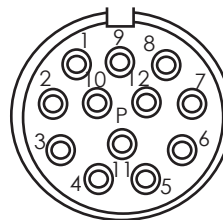

Motor Side: SFMB12TMRSN000
PIN Arrangement

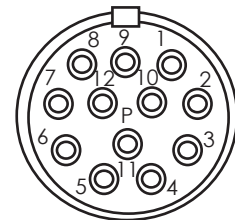

Cable Side: SPNA12SFRON169
PIN Arrangement