

IG 17- F with HS Feedback

Model Numbering

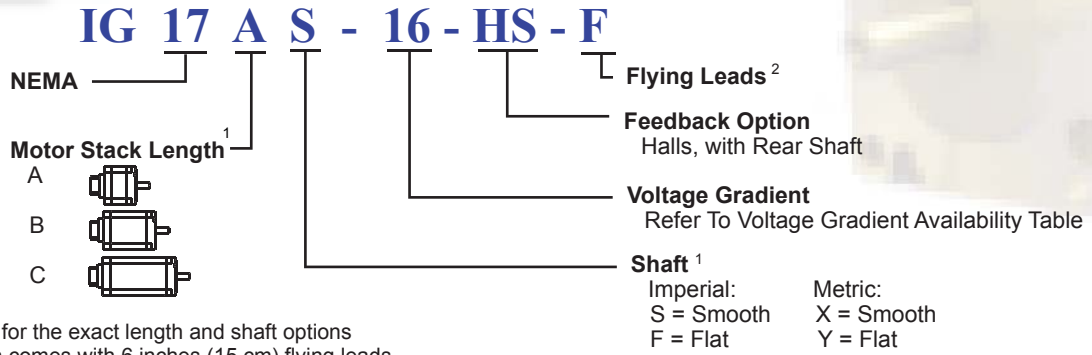

1. Refer to Dimensions for the exact length and shaft options
2. The F housing option comes with 6 inches (15 cm) flying leads

Voltage Gradient

Voltage Constant K_E (V/kRPM)		4	8	11	16
Frame Size	IG 17				

Performance Curves

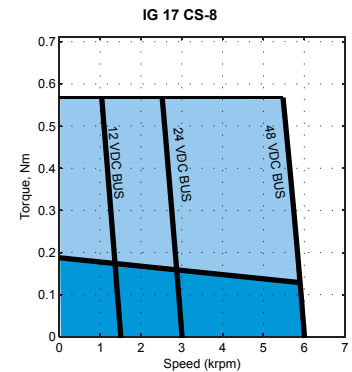
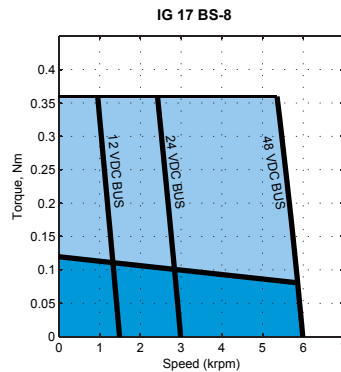
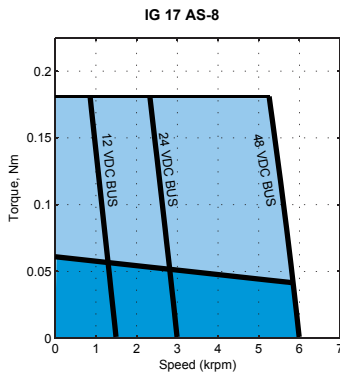

Contact factory for torque-speed curves of other motors

Electrical Specs

NEMA 17																			
Index	Model Number	Weight		Torque Constant (Peak) (L2L)		Voltage Constant	Cont. Stall Torque		Cont. Stall Current		Peak Stall Torque		Peak Stall Current	Max BEMF (Peak) (L2L)	Max Speed	L-to-L Resistance	L-to-L Inductance	Rotor Inertia	
		W		K_T		K_E	T_{cs}		I_{cs}		T_P		I_P	U_{max}	n_{max}	R	L	J	
		kg	lb	Nm/A	lb-in/A	V/krpm	Nm	lb-in	A	Nm	lb-in	A	V	rpm	Ohms	mH	kg-cm ²	lb-in-sec ²	
1	IG 17 AS - 4	0.32	0.71	0.04	0.39	4.00	0.06	0.53	1.36	0.18	1.59	4.08	32.00	8000	0.62	0.53	0.13	0.00012	
2	IG 17 BS - 4	0.48	1.06	0.04	0.39	4.00	0.12	1.06	2.72	0.36	3.19	8.16	32.00	8000	0.27	0.28	0.26	0.00023	
3	IG 17 CS - 4	0.63	1.39	0.04	0.39	4.00	0.19	1.71	4.38	0.57	5.04	12.92	32.00	8000	0.14	0.13	0.39	0.00035	
4	IG 17 AS - 8	0.32	0.71	0.09	0.78	8.00	0.06	0.53	0.68	0.18	1.59	2.04	64.00	8000	2.50	2.10	0.13	0.00012	
5	IG 17 BS - 8	0.48	1.06	0.09	0.78	8.00	0.12	1.06	1.36	0.36	3.19	4.08	64.00	8000	1.05	1.00	0.26	0.00023	
6	IG 17 CS - 8	0.63	1.39	0.09	0.78	8.00	0.19	1.71	2.19	0.57	5.04	6.46	64.00	8000	0.58	0.50	0.39	0.00035	
7	IG 17 AS - 11	0.32	0.71	0.12	1.07	11.00	0.06	0.53	0.49	0.18	1.59	1.48	88.00	8000	5.90	4.70	0.13	0.00012	
8	IG 17 BS - 11	0.48	1.06	0.12	1.07	11.00	0.12	1.06	0.99	0.36	3.19	2.97	88.00	8000	2.30	2.15	0.26	0.00023	
9	IG 17 CS - 11	0.63	1.39	0.12	1.07	11.00	0.19	1.71	1.59	0.57	5.04	4.70	88.00	8000	0.70	1.25	0.39	0.00035	
10	IG 17 AS - 16	0.32	0.71	0.18	1.56	16.00	0.06	0.53	0.34	0.18	1.59	1.02	128.00	8000	10.50	8.40	0.13	0.00012	
11	IG 17 BS - 16	0.48	1.06	0.18	1.56	16.00	0.12	1.06	0.68	0.36	3.19	2.04	128.00	8000	4.10	4.00	0.26	0.00023	
12	IG 17 CS - 16	0.63	1.39	0.18	1.56	16.00	0.19	1.71	1.09	0.57	5.04	3.23	128.00	8000	1.20	2.34	0.39	0.00035	

Feb, 21, 06

IG 17- F with HS Feedback

Motor Drawing

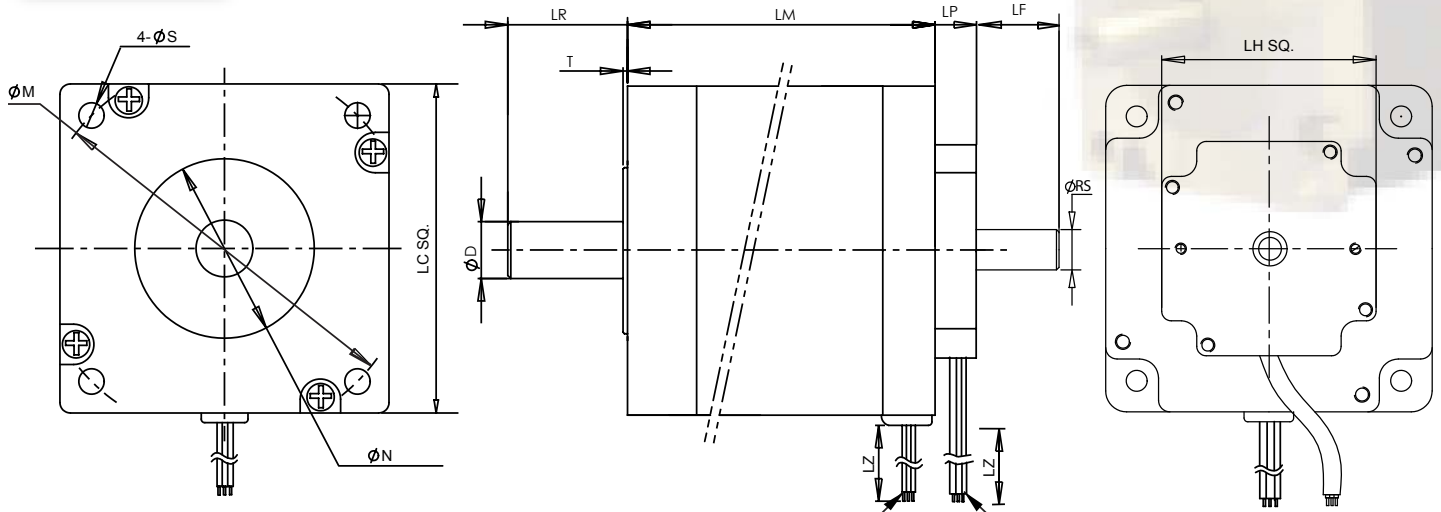

FRONT SHAFT OPTIONS
 (1) SMOOTH SHAFT: AS SHOWN IN THE VIEWS.
 (2) KEYWAY SHAFT

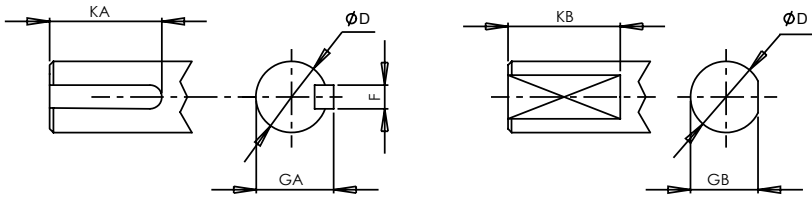

NOTE:
 THE MOTOR HAS IP40 ENCLOSURE
 AND SHAFT PROTECTION.

Units: inches (mm)

IG	LM	T	LR	LC	LZ	LP	LH	LF	Ø RS	N	S	M	
17	A	1.496 (38)	0.079 (2.0)	0.945 (24)	1.665 (42.3)	12 (304.8)	0.354 (9)	1.665 (42.3)	0.650 (16.5)	0.3150 ⁰ _{-0.0005} (8 ⁰ _{-0.013})	0.866 ⁰ _{-0.002} (22.00 ⁰ _{-0.05})	0.118 (3.0) ¹	1.725 (43.82)
	B	2.126 (54)											
	C	2.756 (70)											

¹ S is M3*0.5 min depth 0.2 (5.1) threaded hole

Imperial Shaft Option (S/F/K), Units: inches							Metric Shaft Option (X/Y/Z), Units: mm					
IG	D	F	GA	KA	GB	KB	D	F	GA	KA	GB	KB
17	0.1969 ⁰ _{-0.0005}	-	-	-	0.177 ⁰ _{-0.004}	0.50	5 ⁰ _{-0.013}	-	-	-	4.5 ⁰ _{-0.1}	12.7



Feb, 21, 06

IG 17- F with HS Feedback

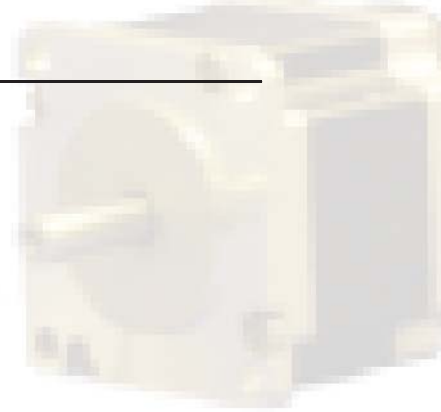

Power Cable Wire Code

Wire Color	Function
YEL	PHASE U
GRN	PHASE V
BLU	PHASE W
GRN/YEL	PE

Hall Sensor

Hall Sensor Electrical Data

Parameter	Values
Supply Voltage, Vcc	Min. 4.5 V Max. 24 V
Supply Current	Max. 11.3 mA
Output Current	Max. 20 mA
Rise Time	Typ. 0.5 μ s Max. 1.5 μ s
Fall Time	Typ. 0.2 μ s Max. 1.5 μ s
Response Time	Typ. 4.0 μ s Max. 5 μ s
Operating Temperature	-40°C to 125°C (-40°F to 257°F)
Storage Temperature	-55°C to 165°C (-67°F to 329°F)

Hall Sensor Wiring Diagram

Wire Color	Function
RED	+Vcc
YEL	HALL U
GRN	HALL V
BLU	HALL W
BLK	GND

Hall Sensor Output Waveforms

