

# IG 23 - F Housing with USX Feedback

## Model Numbering

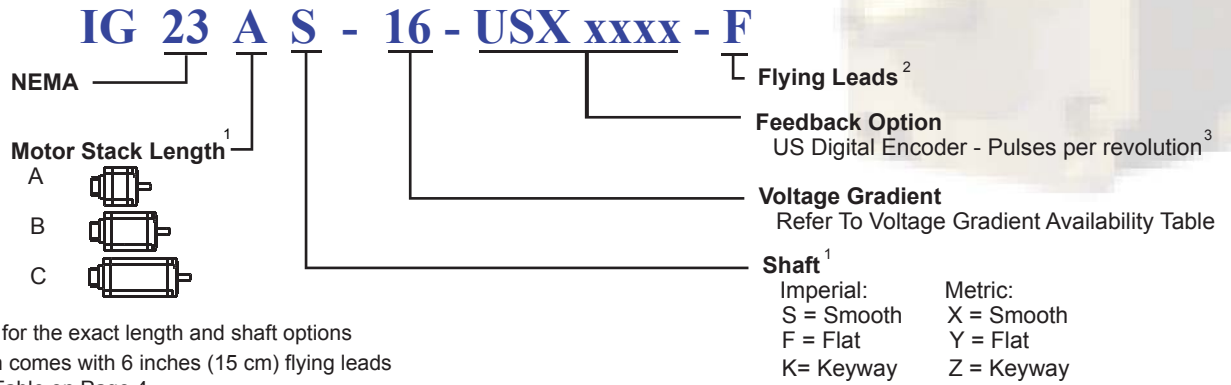

1. Refer to Dimensions for the exact length and shaft options
2. The F housing option comes with 6 inches (15 cm) flying leads
3. Refer to Resolution Table on Page 4

## Voltage Gradient

Voltage Constant $K_E$ (V/kRPM)	8	11	16	22	32	44	64	88	130	180
Frame Size IG 23										

## Performance Curves

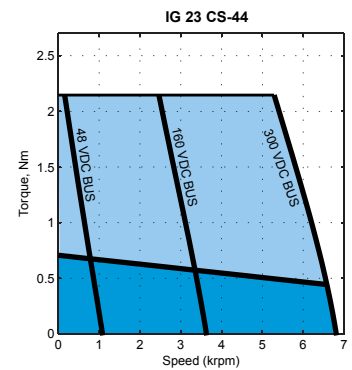
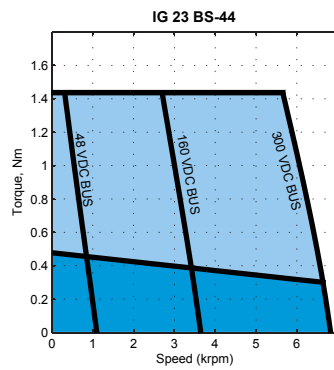
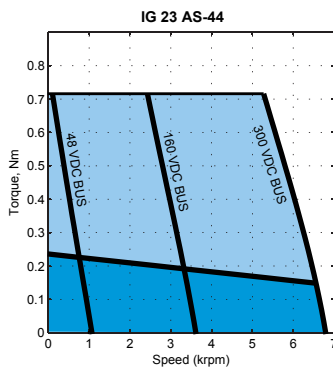

Contact factory for torque-speed curves of other motors

Jan, 19, 07

# IG 23 - F with USX Feedback

## Electrical Specifications

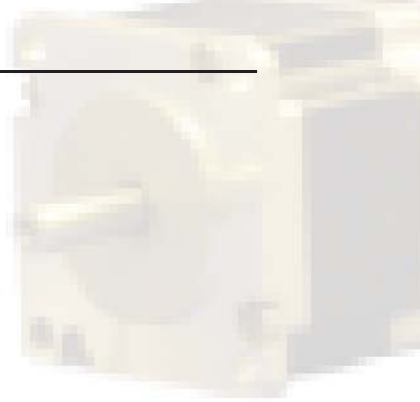

NEMA 23																		
Index	Model Number	Weight		Torque Constant (Peak) (L2L)		Voltage Constant	Cont. Stall Torque		Cont. stall current	Peak Stall Torque		Peak Stall Current	Max BEMF (Peak) (L2L)	Max Speed	L-to-L Resistance	L-to-L Inductance	Rotor Inertia	
		W		K <sub>T</sub>		K <sub>E</sub>	T <sub>cs</sub>	I <sub>cs</sub>	T <sub>P</sub>	I <sub>P</sub>	U <sub>max</sub>	n <sub>max</sub>	R	L	J			
		kg	lb	Nm/A	lb-in/A	V/krpm	Nm	lb-in	A	Nm	lb-in	A	V	rpm	Ohms	mH	kg-cm <sup>2</sup>	lb-in-sec <sup>2</sup>
13	IG 23 AS - 8	0.62	1.37	0.09	0.78	8.00	0.24	2.12	2.72	0.72	6.37	8.16	64.00	8000	0.60	0.72	0.30	0.00
14	IG 23 BS - 8	0.96	2.12	0.09	0.78	8.00	0.48	4.25	5.44	1.44	12.75	16.32	64.00	8000	0.28	0.35	0.60	0.00
15	IG 23 CS - 8	1.20	2.65	0.09	0.78	8.00	0.72	6.37	8.16	2.16	19.12	24.48	64.00	8000	0.21	0.24	0.90	0.00
16	IG 23 AS - 11	0.62	1.37	0.12	1.07	11.00	0.24	2.12	1.98	0.72	6.37	5.94	88.00	8000	1.40	1.90	0.30	0.00
17	IG 23 BS - 11	0.96	2.12	0.12	1.07	11.00	0.48	4.25	3.96	1.44	12.75	11.87	88.00	8000	0.55	0.75	0.60	0.00
18	IG 23 CS - 11	1.20	2.65	0.12	1.07	11.00	0.72	6.37	5.94	2.16	19.12	17.81	88.00	8000	0.45	0.60	0.90	0.00
19	IG 23 AS - 16	0.62	1.37	0.18	1.56	16.00	0.24	2.12	1.36	0.72	6.37	4.08	128.00	8000	2.65	3.20	0.30	0.00
20	IG 23 BS - 16	0.96	2.12	0.18	1.56	16.00	0.48	4.25	2.72	1.44	12.75	8.16	128.00	8000	1.00	1.35	0.60	0.00
21	IG 23 CS - 16	1.20	2.65	0.18	1.56	16.00	0.72	6.37	4.08	2.16	19.12	12.24	128.00	8000	0.78	1.10	0.90	0.00
22	IG 23 AS - 22	0.62	1.37	0.24	2.15	22.00	0.24	2.12	0.99	0.72	6.37	2.97	176.00	8000	5.90	9.30	0.30	0.00
23	IG 23 BS - 22	0.96	2.12	0.24	2.15	22.00	0.48	4.25	1.98	1.44	12.75	5.94	176.00	8000	2.20	2.90	0.60	0.00
24	IG 23 CS - 22	1.20	2.65	0.24	2.15	22.00	0.72	6.37	2.97	2.16	19.12	8.90	176.00	8000	1.80	2.40	0.90	0.00
25	IG 23 AS - 32	0.62	1.37	0.35	3.12	32.00	0.24	2.12	0.68	0.72	6.37	2.04	256.00	8000	15.20	18.20	0.30	0.00
26	IG 23 BS - 32	0.96	2.12	0.35	3.12	32.00	0.48	4.25	1.36	1.44	12.75	4.08	256.00	8000	6.20	7.10	0.60	0.00
27	IG 23 CS - 32	1.20	2.65	0.35	3.12	32.00	0.72	6.37	2.04	2.16	19.12	6.12	256.00	8000	4.60	5.70	0.90	0.00
28	IG 23 AS - 44	0.62	1.37	0.49	4.29	44.00	0.24	2.12	0.49	0.72	6.37	1.48	352.00	8000	28.50	35.60	0.30	0.00
29	IG 23 BS - 44	0.96	2.12	0.49	4.29	44.00	0.48	4.25	0.99	1.44	12.75	2.97	352.00	8000	11.50	14.10	0.60	0.00
30	IG 23 CS - 44	1.20	2.65	0.49	4.29	44.00	0.72	6.37	1.48	2.16	19.12	4.45	352.00	8000	9.10	12.30	0.90	0.00
31	IG 23 AS - 64	0.62	1.37	0.71	6.25	64.00	0.24	2.12	0.34	0.72	6.37	1.02	512.00	8000	67.20	80.90	0.30	0.00
32	IG 23 BS - 64	0.96	2.12	0.71	6.25	64.00	0.48	4.25	0.68	1.44	12.75	2.04	512.00	8000	26.90	33.10	0.60	0.00
33	IG 23 CS - 64	1.20	2.65	0.71	6.25	64.00	0.72	6.37	1.02	2.16	19.12	3.06	512.00	8000	21.30	27.60	0.90	0.00
34	IG 23 AS - 88	0.62	1.37	0.97	8.59	88.00	0.24	2.12	0.25	0.72	6.37	0.74	704.00	8000	107.00	134.50	0.30	0.00
35	IG 23 BS - 88	0.96	2.12	0.97	8.59	88.00	0.48	4.25	0.49	1.44	12.75	1.48	704.00	8000	43.30	54.50	0.60	0.00
36	IG 23 CS - 88	1.20	2.65	0.97	8.59	88.00	0.72	6.37	0.74	2.16	19.12	2.23	704.00	8000	35.80	45.20	0.90	0.00
37	IG 23 AS - 130	0.62	1.37	1.43	12.69	130.00	0.24	2.12	0.17	0.72	6.37	0.50	1,040.00	8000	170.20	212.50	0.30	0.00
38	IG 23 BS - 130	0.96	2.12	1.43	12.69	130.00	0.48	4.25	0.33	1.44	12.75	1.00	1,040.00	8000	68.50	86.84	0.60	0.00
39	IG 23 CS - 130	1.20	2.65	1.43	12.69	130.00	0.72	6.37	0.50	2.16	19.12	1.51	1,040.00	8000	56.70	71.80	0.90	0.00
40	IG 23 AS - 180	0.62	1.37	1.98	17.57	180.00	0.24	2.12	0.12	0.72	6.37	0.36	1,440.00	8000	307.40	406.50	0.30	0.00
41	IG 23 BS - 180	0.96	2.12	1.98	17.57	180.00	0.48	4.25	0.24	1.44	12.75	0.73	1,440.00	8000	131.00	166.10	0.60	0.00
42	IG 23 CS - 180	1.20	2.65	1.98	17.57	180.00	0.72	6.37	0.36	2.16	19.12	1.09	1,440.00	8000	101.00	136.70	0.90	0.00

L2L: Line-to-Line

# IG 23 - F with USX Feedback

## Drawing

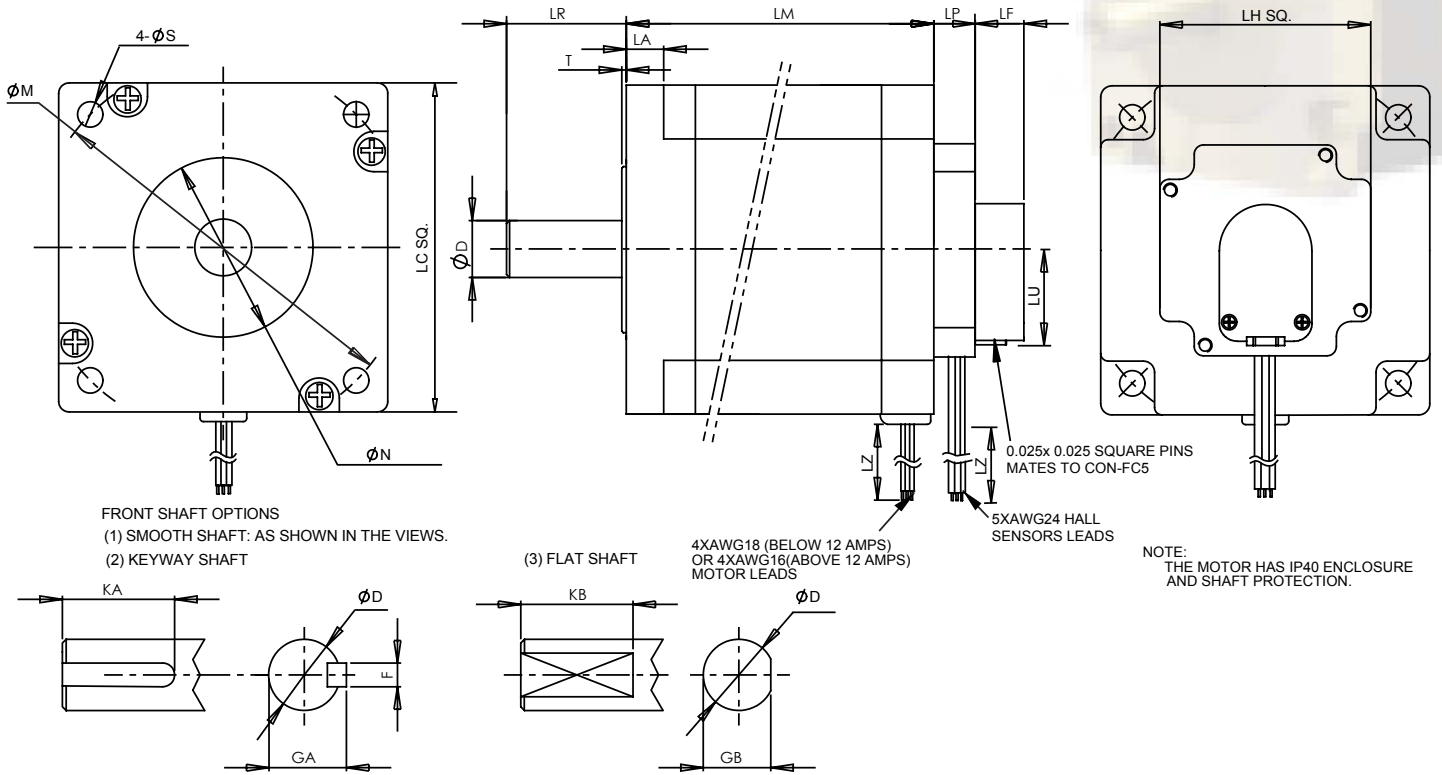

Units: Inches (mm)

IG	LM	LF	LA	T	LR	LC	LP	LH	LZ	LU	N	S	M	
23	A	1.890 (48)	0.640 (16.3)	0.20 (5.1)	0.060 (1.5)	0.825 (21)	2.220 (56.4)	0.433 (11)	2.220 (56.4)	12 (304.8)	1.251 (31.7)	1.500 <sup>0</sup> <sub>-0.002</sub> (38.10 <sup>0</sup> <sub>-0.05</sub> )	0.200 (5.1)	2.625 (66.675)
	B	2.717 (69)												
	C	3.543 (90)												

IG	Imperial Shaft Option (S/F/K), Units: Inches						Metric Shaft Option (X/Y/Z), Units: mm					
	D	F	GA	KA	GB	KB	D	F	GA	KA	GB	KB
23	0.3750 <sup>0</sup> <sub>-0.0005</sub>	0.0938 <sup>0</sup> <sub>-0.001</sub>	0.416 <sup>0</sup> <sub>-0.002</sub>	0.50	0.340 <sup>0</sup> <sub>-0.004</sub>	0.50	10 <sup>0</sup> <sub>-0.013</sub>	3 <sup>0</sup> <sub>-0.025</sub>	11.2 <sup>0</sup> <sub>-0.051</sub>	15	9.0 <sup>0</sup> <sub>-0.1</sub>	15.0



Jan, 19, 07

# IG 23 - F with USX Feedback

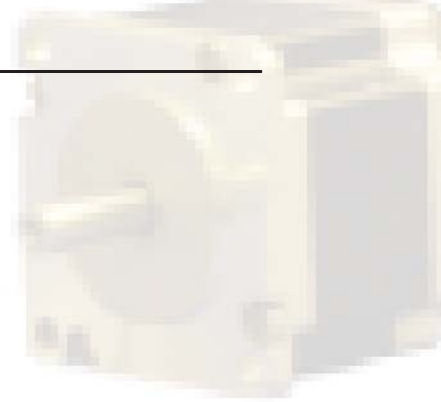

## Power Cable Wire Code

Wire Color	Function
YEL	PHASE U
GRN	PHASE V
BLU	PHASE W
GRN/YEL	PE

## Hall Sensor

### Hall Sensor Electrical Data

Parameter	Values
Supply Voltage, Vcc	Min. 4.5 V Max. 24 V
Supply Current	Max. 11.3 mA
Output Current	Max. 20 mA
Rise Time	Typ. 0.5 $\mu$ s Max. 1.5 $\mu$ s
Fall Time	Typ. 0.2 $\mu$ s Max. 1.5 $\mu$ s
Response Time	Typ. 4.0 $\mu$ s Max. 5 $\mu$ s
Operating Temperature	-40°C to 125°C (-40°F to 257°F)
Storage Temperature	-55°C to 165°C (-67°F to 329°F)

### Hall Sensor Output Waveforms

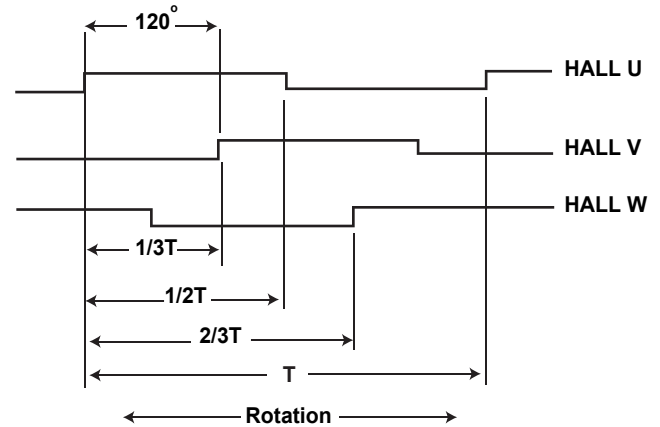

T = Electrical Period

### Hall Sensor Wiring Diagram

Wire Color	Function
RED	+Vcc
YEL	HALL U
GRN	HALL V
BLU	HALL W
BLK	GND

## US Encoder

### US Digital Encoder Data

Parameter	Values
Input Voltage, Vcc	Typ. +5VDC Min. 4.5 VDC Max. 5.5 VDC
Input Current Requirement	Typ. 57 mA Min. 30 mA Max. 85 mA
Output Voltage	Min. -0.5 VDC Max. Vcc
Output Current Per Channel	Min. -8.0 mA Max. 8.0 mA
Output Data	Incremental - Two square waves in quadrature with channel A leading B for clockwise shaft rotation as viewed from the encoder mounting face
Output Format	TTL level output
Frequency Response	100 kHz
Minimum Edge Separation	45° electrical angle
Maximum Speed	6000 rpm
Operating Temperature	-40°C to 100°C
Storage Temperature	-15°C to 85°C
Available line counts	32 to 1250 ppr

### E5S Encoder Wiring Diagram

Pin No.	Function
1	GND
2	INDEX
3	CH A
4	+5VDC
5	CH B

### Encoder Output Waveforms

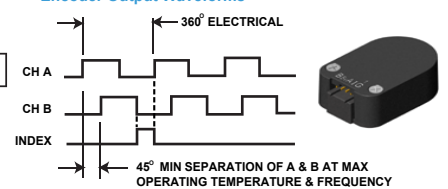

Mating Connector: CON-FC5-22AWG



### E5D Encoder Wiring Diagram

Wire #	Function
1	Ground
2	Ground
3	Index-
4	Index+
5	A- channel
6	A+ channel
7	+5VDC power
8	+5VDC power
9	B- channel
10	B+ channel

### Encoder Output Waveforms

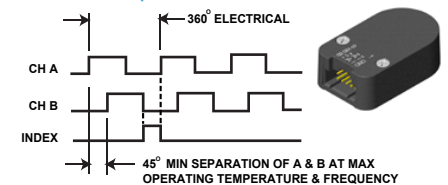

Mating Connector: CON-FC10

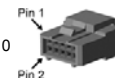

Jan, 11, 07